



NEWAGE[®]
GROUP OF COMPANIES

Protection with Reliability and Trust



2017
EDITION



NewAge Group of Companies

Consisting of...



NEWAGE
HOSE MFG. CO.



NK Fire & Safety
(Division of NewAge Fire Fighting Co. Ltd.)



ARMTEX
RUBBER PVT. LTD.

NewAge was founded in the year of 1960 at Surendranagar, Gujarat and it has more than 5 decades of experience of manufacturing of various kinds of Fire Fighting Equipments and Fire Fighting Delivery Hoses. **NewAge Group of Companies** has the factories spread over 50,000 square meters at Surendranagar. It has its regional offices in New Delhi, Ahmedabad, Pune, Chennai, Kochi, Vadodara, Kolkata and Bangalore. **NewAge** also sells its equipments through its efficient network of agents throughout India. **NewAge** has more than 45 years of experience in selling its products abroad as well and today it exports the products to 60 countries. Since its inception, **NewAge** has grown to become the only manufacturer in the subcontinent to provide the complete range of firefighting equipments starting from fire hoses, hydrants, water foam monitors, foam equipments to fire vehicles and is indisputably the leading manufacturer of these products. It is considered a benchmark in the fire industry due to its consistent and quality based principle.

NewAge Group has successfully acquired Jayshree Textiles – A Division of Indian Rayon Corporation, Aditya Birla Group in 2003 and Hose Division of one of the other international companies in the year of 2006 making **NewAge** Group, Asia's largest production for the Fire Fighting Hoses with daily production capacity of 20,000 meters. **NewAge Group of Companies** are backward integrated and fully self reliant for its production activities with own foundry and machine shop with daily casting capacity of 2,000 kilograms.

NewAge has been a regular supplier of approved and quality goods to sectors like Oil and Gas, Chemical and Fertilizer, Power Plants, Aviation Industry, Construction and Infrastructure, Port Trusts, Defense Establishments and other industries.

The Group of Companies employs about 500 people. It is a regular recipient of Export Excellence Awards for exporting the products to countries like Singapore, Malaysia, Kuwait, Kenya, Myanmar, Indonesia, United Kingdom, Italy, Germany, Denmark, Belgium Greece, Canada, Ireland, United States of America, Canada, South Africa, United Arab Emirates, Philippines etc.

Profile	2
Index	3
Quality Assurance	4
Applications	5
Fire Hose & Fittings	
Fire Hoses	6
Delivery Hose Couplings	9
Adapters & Caps	11
Collecting & Dividing Breeching	14
Valves	
Hydrant Valves	15
Pressure Control Devices	18
Dry Riser Fittings	19
Gate Valves	20
Butterfly Valves	22
Cabinet	
Hose Box	23
Hose Reels	
Hose Reel & Accessories	25
Pillar Hydrants and Nozzles	
Standpost	28
Standpipe, Hydrant & Key	30
Branch Pipes	32
Pistol-Grip Nozzles	36
Water Spray Nozzles	39
Foam Equipments	
Foam Branch Pipes	41
Foam Generators	42
Foam Inductors	44
Foam Makers	45
Mobile Foam Units	46
Monitors & Nozzles	
Carbon Steel Monitors	47
Portable Monitors	48
Trailer / Trolley / Standpost Mounted Monitors	49
UL Listed Monitors	50
Remote Operated Monitors	52
Monitor Nozzles	53
Pumps & Accessories	
Fire Vehicle Pumps	56
Fire Fighting Pumps	58
Water Driven Dewatering Pumps	59
Accessories	60
Miscellaneous Equipments	
Hose Maintenance Equipments	61
Warning / Other Appliances	63
Smoke Extractor & Blower	64
Fire Vehicles	
Fire Vehicles	65
Special Purpose Vehicles	68
Skid Mounted Equipments	69
Environment Protection Equipments	71
Rescue Equipment	73



At NewAge Group of Companies, when it comes to fire protection of people and property, there is no scope for error because we believe it our responsibility to be the good stewards of safety. For complete customer satisfaction and safety, quality is ingrained in our work and our values.

Since its inception, the Company endeavors to continually and effectively improve the quality of its products and services in accordance with the International standards. As a part of our quality policy, our fire equipment meet the ISO 9001:2008 guidelines and we are accredited by numerous National and International regulatory bodies for the remarkable quality of our work. At each phase of production, our quality control personnel rigorously tests and examines the performance and durability to present our customers with the finest portfolio of products. At NewAge, we have a relentless passion for quality as we aim to make the community, a safer and better place to live.



Underwriters Laboratory



APPROVED
Factory Mutual



Conformité Européene

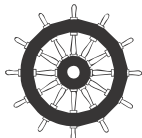

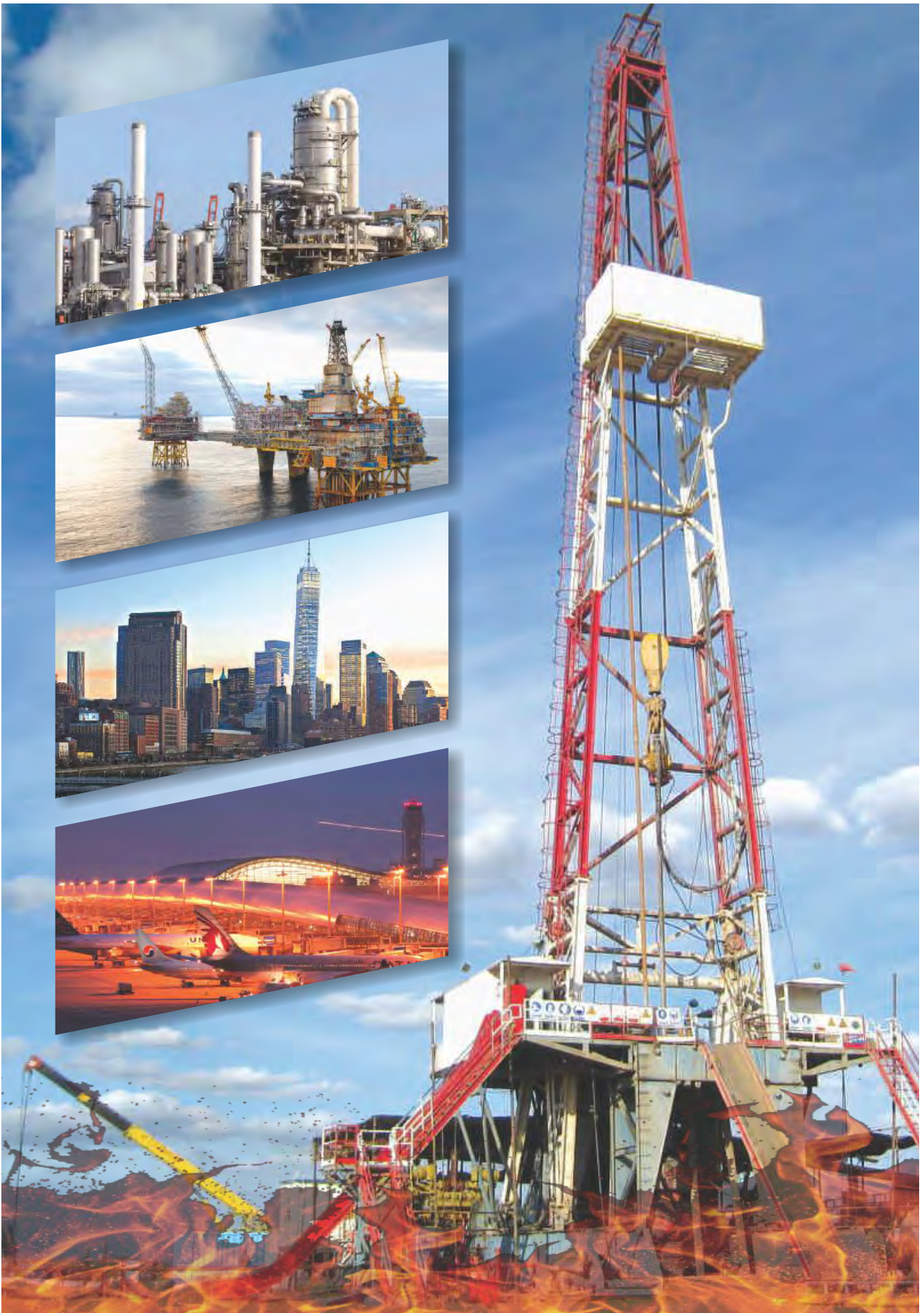

Premier Fire Hose

- ◆ Premium quality Rubber lined Single Jacket Hose
- ◆ Circular woven Jacket made up of 100% Polyester yarn
- ◆ High Quality Synthetic EPDM Rubber Lining
- ◆ Light and Flexible, Sea Water and Weather Resistant, Ageing and Ozone Resistant
- ◆ ISI Marked
- ◆ UL Listed
- ◆ Germanischer Lloyd's Approved
- ◆ M.E.D. 96/98/EC  Approved
- ◆ Conforming to BS 6391:2009 Type 1



Item Code # NFF-FH-PR

Diameter		Bursting Pressure		Working Pressure	
in mm	in inch	in bar	in psi	in bar	in psi
25	1	60	870	18	260
38	1 ½	60	870	18	260
45	1 ¾	60	870	18	260
52	2	55	800	17	250
65	2 ½	55	800	17	250
70	2 ¾	50	725	16	235
76	3	45	650	14	205
102	4	40	580	12	175
127	5	35	510	10	145
152	6	30	435	10	145

Premier Extra Fire Hose

- ◆ Designed for Aggressive Fire Fighting Applications
- ◆ Circular woven Jacket made up of 100% Polyester yarn
- ◆ High Quality Synthetic EPDM Rubber Lining
- ◆ External Coating of specially formulated Synthetic Elastomer
- ◆ Heat and Abrasion Resistant
- ◆ ISI Marked
- ◆ Germanischer Lloyd's Approved
- ◆ M.E.D. 96/98/EC  Approved
- ◆ Conforming to BS 6391:2009 Type 2
- ◆ Available Colors – Red, Yellow, Blue, Orange, Green, Black



Item Code # NFF-FH-PE

Diameter		Bursting Pressure		Working Pressure	
in mm	in inch	in bar	in psi	in bar	in psi
25	1	60	870	18	260
38	1 ½	60	870	18	260
45	1 ¾	60	870	18	260
52	2	55	800	17	250
65	2 ½	55	800	17	250
70	2 ¾	50	725	16	235
76	3	45	650	14	205
102	4	40	580	12	175
127	5	35	510	10	145
152	6	30	435	10	145

Pyroprotect Fire Hose



Item Code # NFF-FH-PP

- ◆ Heavy Duty Fully Extruded "Thru-the-Weave" Delivery Hose
- ◆ 100% High Tenacity Polyester / Polyamide Circular Woven Reinforcement
- ◆ Embedded in a high quality special grade of Nitrile / PVC Rubber Compound
- ◆ Ribs on External Cover provides very high Abrasion Resistance and Ease of Handling
- ◆ Resistant to Oil, Fuel & Chemicals, Resistant to Kink
- ◆ Extremely Long Service Life
- ◆ Maintenance Free & Easy to Repair
- ◆ ISI Marked
- ◆ UL Listed
- ◆ Germanischer Lloyd's Approved
- ◆ M.E.D. 96/98/EC Approved
- ◆ Conforming to BS 6391:2009 Type 3
- ◆ Available Colors – Red, Yellow, Blue, Black

Diameter		Bursting Pressure		Working Pressure	
in mm	in inch	in bar	in psi	in bar	in psi
25	1	60	870	18	260
38	1 ½	60	870	18	260
45	1 ¾	60	870	18	260
52	2	55	800	17	250
65	2 ½	55	800	17	250
70	2 ¾	50	725	16	235
76	3	45	650	14	205
102	4	40	580	12	175
127	5	35	510	10	145
152	6	30	435	10	145

Watershield Fire Hose



Item Code # NFF-FH-WS

- ◆ Forestry Light Weight, Self-Protecting, Attack Hose
- ◆ Circular woven Jacket made up of 100% Polyester yarn
- ◆ Smooth Rubberized Water Way for Uniform Controlled Percolation and Even Wetting
- ◆ Flame Resistant
- ◆ Also used in for Irrigation, Bush Fires any other Unmanned Areas
- ◆ ISI Marked
- ◆ Conforming to Australian Standard 2792-92, Canadian Standard ULC S519.1-95, New Zealand standard (NRFA) 1998

Diameter		Bursting Pressure		Working Pressure	
in mm	in inch	in bar	in psi	in bar	in psi
25	1	50	725	18	260
38	1 ½	50	725	18	260
45	1 ¾	50	725	18	260
52	2	45	650	17	250
65	2 ½	45	650	17	250
70	2 ¾	45	650	15	220

Premier Dj / Hydroline

- ◆ Double Jacketed Super Strong Premium Construction Hose.
- ◆ Designed and manufactured for Fire Brigade and Heavy
- ◆ Industrial Fire Fighting applications where high water pressure is required
- ◆ Jackets are made of 100% polyester yarns, seamless woven on circular weaving looms
- ◆ Inner jacket has extruded tubing of EPDM polymer
- ◆ High Burst Pressure yet Excellent Flexibility
- ◆ Suitable for use with C.A.F.S and Foam Solution
- ◆ Optional : Coating with Red Colored Synthetic Elastomer. Other Color available upon request
- ◆ Manufactured in accordance with NFPA 1961
- ◆ Conforming to UL 19 Standard



Item Code # NFF-FH-PDJ (Uncoated) & NFF-FH-HL (Coated)

Diameter		Bursting Pressure		Working Pressure	
in mm	in inch	in bar	in psi	in bar	in psi
38	1 ½	84	1200	27	400
52	2	84	1200	27	400
65	2 ½	84	1200	27	400

Hose Component

HOSE GUARD

- ◆ Made up of 100% Synthetic Polyester Yarn
- ◆ Protects Hose from Binding Wire
- ◆ Diameter from 15 mm up to 150 mm available diameters on request
- ◆ Different colors and yarn types on request

RUBBER COVER

- ◆ Made up of 100% Synthetic Rubber
- ◆ Covers Binding Wire protecting the hands of personnel
- ◆ Diameter from 15 mm up to 150 mm

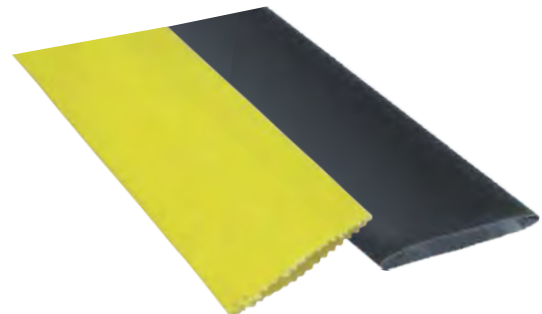



- ◆ As per BS 336 and IS 903
- ◆ Body – Gunmetal / Aluminum Alloy / Stainless Steel
- ◆ Working Pressure – 10 bar
- ◆ Test Pressure – 23 bar
- ◆ Aluminum couplings available in natural polish as well as hard anodized
- ◆ Gunmetal couplings also available in Chrome finish

Item Code # NFF-CP-IS

Description	Types	Material of Construction
2.5" Inst x 38mm Hose Tail	Ribbed Multi - Serrated	Gunmetal Aluminum Alloy Stainless Steel
2.5" Inst x 45mm Hose Tail		
2.5" Inst x 52mm Hose Tail		
2.5" Inst x 64mm Hose Tail		
2.5" Inst x 70mm Hose Tail		
2" Inst x 64mm Hose Tail		
1.5" Inst x 38mm Hose Tail		

*Few Models Available

American Rocker Lug (NH) Couplings



- ◆ Used with Single and Double Jacketed lined hose.
- ◆ Provides more strength
- ◆ Body – Gunmetal / Aluminum Alloy
- ◆ Complete with expansion rings and swivel washer

Item Code # NFF-CP-RL

Dia Size	Hose Tail	Finish
1.5"	38mm	Gunmetal Chrome Aluminum Natural Finish Hard Anodised Aluminum
1.5"	45mm	
2.5"	38mm	
2.5"	45mm	
2.5"	52mm	
2.5"	64mm	
2.5"	70mm	
2.5"	75mm	

Russian Gost Coupling

Item Code # NFF-CP-GS

Dia Size	Hose Tail	Finish
Gost 50	38mm	Gunmetal Chrome Aluminum Natural Finish Hard Anodised Aluminum
Gost 50	52mm	
Gost 70	38mm	
Gost 70	52mm	
Gost 70	64mm	
Gost 80	64mm	
Gost 80	75mm	



Storz Coupling

- ◆ Both halves on the coupling are identical so either half can be connected to any similar size coupling.
- ◆ Distance between locking ears should be same on all fittings
- ◆ Body – Gunmetal / Aluminum Alloy
- ◆ Max working pressure – 16 bar
- ◆ Coupling with reduced shank also available

Item Code # NFF-CP-ST

Size	Finish
Storz Coupling for 1.5" Hose	Gunmetal Aluminum Alloy
Storz Coupling for 2" Hose	
Storz Coupling for 2.5" Hose	
Storz Coupling for 3" Hose	
Storz Coupling for 4" Hose	
Storz Coupling for 5" Hose	
Storz Coupling for 6" Hose	



Suction Coupling

- ◆ As per BS 336 / IS 902
- ◆ Body – Gunmetal / Aluminum
- ◆ Connection Threads – British Standard Round Thread

Item Code # NFF-CP-ST

Size	Finish
3"	Gunmetal Aluminum Alloy
4"	
5"	
5.5"	



Instantaneous Adaptor



- ◆ Body : Gun Metal / Aluminum Alloy
- ◆ Size : 1.5" / 2.5"
- ◆ Working Pressure : 10 Bar
- ◆ Hydro Test Pressure : 25 Bar

Item Code # NFF-ADP-IA

One End	Other End	Material of Construction
1.5" / 2.5" Male / Female Instantaneous	1.5" / 2.5" BSP / NST / NH / Male / Female Threads	Gunmetal
1.5" / 2.5" Male / Female Instantaneous	1.5" / 2.5" Male / Female Instantaneous	Aluminum Alloy

Threaded Adaptor



- ◆ Body : Gun Metal or Aluminum Alloy
- ◆ Size : 1.5 / 2.5
- ◆ Working Pressure : 10 Bar
- ◆ Hydro Test Pressure : 25 Bar

Item Code # NFF-ADP-TA

One End	Other End	Material of Construction
1.5" / 2.5" BSP / NST / NH / Male / Female Threads	1.5" / 2.5" BSP / NST / NH / Male / Female Threads	Gunmetal Aluminum Alloy

Blank Caps & Chain



Item Code # NFF-ADP-BC&C

Size	Material of Construction
1.5" / 2.5" Male / Female Instantaneous	Gunmetal
2.5 Male Instantaneous	ABS / PVC
1.5" / 2.5" Storz	Gunmetal

Storz Adaptor

Item Code # NFF-ADP-SA

One End	Other End	Material of Construction
1.5" / 2.5" Storz	1.5" / 2 / 2.5" BSP / NST / NH Male / Female Threads	Gunmetal



Gost Adaptor

- ◆ Body : Gun Metal / Aluminum Alloy
- ◆ Size : 1.5" / 2.5"
- ◆ Working Pressure : 10 Bar
- ◆ Test Pressure : 25 Bar

Item Code # NFF-ADP-GA

One End	Other End	Material of Construction
1.5" / 2.5" Gost	1.5" / 2 / 2.5" BSP / NST / NH Male / Female Threads	Gunmetal Aluminum Alloy



Flange Adaptor



- ◆ Flange adaptors are either the standard flange adaptors or international shore adaptors.
- ◆ Standard flange adaptors basically are of 3 types – ANSI / Table D or PN16 flanges. These comes with any international adaptor.
- ◆ They are also available with NRV (optional)
- ◆ International Shore connections are based on a fixed flange size (178mm Diameter / 132mm PCD) and supplied with 19mm slots for fitting. They come with any international adaptor.

Item Code # NFF-ADP-FA

One End	Other End	Material of Construction
Flanges as per ANSI / PN16 / Table D	1.5" / 2" / 2.5" BSP / NPT / NH Male / Female threads	Gunmetal
	1.5" / 2.5" Male / Female Instantaneous	Aluminum Alloy

BSRT Adaptor



Item Code # NFF-ADP-BSRTA

One End	Other End	Material of Construction
4" / 5" / 5.5" Male / Female BSRT	1.5" / 2" / 2.5" BSP / NST / NH Male / Female Threads	Gunmetal Aluminum Alloy
	1.5" / 2.5" Male / Female Instantaneous	
	4" / 5" / 5.5" Male / Female BSRT	

Pumper Adaptor



Item Code # NFF-ADP-PA

Type	One End	Other End	Material of Construction
BSRT Pumper Adaptor	4" / 5" / 5.5" BSRT	Any Flange or 4" / 5" NPT threads	Gunmetal Aluminum Alloy
Storz Pumper Adaptor	4" / 5" Storz	Any Flange or 4" / 5" NPT threads	

Collecting & Dividing Breeching

Dividing Breeching



- ◆ Single Water Supply Hose divided into Multiple Hose lines for enhanced water delivery
- ◆ Standard version without Control arrangement
- ◆ Controlled versions are available with Ball Valve or Screw Down type valve for each dividing line
- ◆ Swivel Connection available on Request

Item Code # NFF-FT-DB

Inlet	Outlet	Connection	Lines	Material of Construction
4 Inch 3 Inch 2.5 Inch	4 Inch 3 Inch 2.5 Inch	British Standard Instantaneous Storz Coupling Russian GOST American NST Rocker Lug BSRT Threaded	2 Way 3 Way 4 Way	Gunmetal Aluminium Alloy

Collecting Breeching



- ◆ Two or Multiple Hose Lines merged into Single Water Supply Line for Higher and effective Water delivery
- ◆ Standard version without Control arrangement
- ◆ Controlled versions are available with Spring loaded Non Return Valve, Ball Valve or Screw Down type valve for each dividing line
- ◆ Swivel Connection available on Request

Item Code # NFF-FT-CB

Inlet	Outlet	Connection	Lines	Material of Construction
4 Inch 3 Inch 2.5 Inch	4 Inch 3 Inch 2.5 Inch	British Standard Instantaneous Storz Coupling Russian GOST American NST Rocker Lug BSRT Threaded	2 Way 3 Way 4 Way	Gunmetal Aluminium Alloy

Hydrant Valve



Oblique Flanged - FM Approved



Newage FM Landing Valve is used to form a complete Wet Riser System for intense high pressure Fire Fighting Applications.

Item Code	Size	Inlet	Outlet	Test Pressure	Material of Construction
NFF-HV-FM-GM	2 1/2"	3" Flanged	2 1/2" Female Instantaneous / NH (M) / NST (M) / BSP (M) Threaded	700 PSI	Gunmetal
NFF-HV-FM-SS					Stainless Steel

Oblique Flanged - ISI Marked



- ◆ Newage ISI Marked Landing Valve, as per IS:5290-1993, is designed for the primary Fire Fighting Application
- ◆ Body of the Valve and the Internals are tested at 300 psi or 21 Kg/cm²
- ◆ Compact with Excellent Flow Characteristics
- ◆ Generally conforming to BS:5041 Part 1

Item Code	Size	Inlet	Outlet	Test Pressure	Material of Construction
NFF-HV-OF-GM	2 1/2"	3" Flanged	2 1/2" Female Instantaneous	300 PSI	Gunmetal
NFF-HV-OF-SS					Stainless Steel
NFF-HV-OF-AL					Aluminum Alloy

Double Headed Hydrant - ISI Marked



- ◆ Newage Double Headed Hydrant Valve are designed and manufactured as per IS:5290-1993
- ◆ Highly Durable and Corrosion Resistant
- ◆ Excellent Flow Characteristics

Item Code	Size	Inlet	Outlet	Test Pressure	Material of Construction
NFF-HV-DHV-GM	2 1/2"	4" Flanged	2 1/2" Female Instantaneous	300 PSI	Gunmetal
NFF-HV-DHV-SS					Stainless Steel

Oblique Threaded

Item Code	Size	Inlet	Outlet	Test Pressure	Material of Construction
NFF-HV-OT-GM	1 1/2" 2 1/2" 3	3" Flanged	2 1/2" Female Instantaneous / NH (M) / NST (M) / BSP (M) Threaded	300 PSI	Gunmetal



Bib Nose Type Valve

Item Code	Size	Inlet	Outlet	Test Pressure	Material of Construction
NFF-HV-BN-GM	2 1/2" 3	3" Flanged BSP (M) Thread NP (M) Thread	2 1/2" Female Instantaneous / NH (M) / NST (M) / BSP (M) Threaded	300 PSI	Gunmetal



Right Angled Flanged

Item Code	Size	Inlet	Outlet	Test Pressure	Material of Construction
NFF-HV-RA-GM	2 1/2"	3" Flanged BSP (M) Thread NP (M) Thread	2 1/2" Female Instantaneous / NH (M) / NST (M) / BSP (M) Threaded	300 PSI	Gunmetal



Turn Down Flanged



Item Code	Size	Inlet	Outlet	Test Pressure	Material of Construction
NFF-HV-TD-GM	2 1/2"	3" Flanged BSP (M) Thread NP (M) Thread	2 1/2" Female Instantaneous / NH (M) / NST (M) / BSP (M) Threaded	300 PSI	Gunmetal

Straight Valve



Item Code	Size	Inlet	Outlet	Test Pressure	Material of Construction
NFF-HV-ST-GM	2 1/2"	3" Flanged BSP (M) Thread NP (M) Thread	2 1/2" Female Instantaneous / NH (M) / NST (M) / BSP (M) Threaded	300 PSI	Gunmetal

Gate Valve



Item Code	Size	Inlet	Outlet	Test Pressure	Material of Construction
NFF-HV-GV-GM	2 1/2"	3" Flanged BSP (M) Thread NP (M) Thread	2 1/2" Female Instantaneous / NH (M) / NST (M) / BSP (M) Threaded	300 PSI	Gunmetal

Hose Valve



Item Code	Description
NFF-HV-HV-GM	1 1/2" (F) NPT × 1 1/2" (F) NST (NH)
	1 1/2" (F) NPT × 1 1/2" (M) NST (NH)
	2 1/2" (F) NPT × 2 1/2" (F) NST (NH)
	2 1/2" (F) NPT × 2 1/2" (M) NST

Class F Pressure Regulating Valve

Item Code # NFF-LV-PRV

- ◆ The class F Pressure Regulating Valve combines features of a Hydrant Valve and Pressure Control Device.
- ◆ Designed for Applications like High Rise Buildings, High Pressure Lines in Oil & Gas, For Assemblies requiring different pressures for Optimum working, Long Water Mains etc
- ◆ Helps in maintaining Uniform Range of Outlet Pressure irrespective of its Location Eliminates the problems faced by the Fire Fighters of sudden surge and decline in pressure
- ◆ hindering the effective control of Hose Line.
- ◆ Expensive Pressure Relief Piping is eliminated
- ◆ Field Adjustable Pressure Regulator that could be tuned to meet Individual Floor level pressure requirements.
- ◆ Spring loaded Balanced Pressure reducing Mechanism.
- ◆ The main advantage of Pressure Regulating Valve is controlled outlet pressure irrespective of Inlet Pressure without compromising the Flow
- ◆ Gunmetal Construction for Corrosion Resistance and Sea Water Application
- ◆ Design and Construction confirming to BS:5041

Pressure Range

Outlet : 4.1 - 5.5 Bar (60 - 80 Lbs/in²)
5.5 - 8.3 Bar (80 - 120 Lbs/in²)

Inlet : 4.8 - 20.7 Bar (70 - 300 Lbs/in²)

Connections

Outlet : 2 ½" Instantaneous female coupling to BS: 336.

Inlet : (a) 1 ½" Flanged inlet suitable for ANSI - 150 Lbs, BS 4504 - Pn16, BS - 10 Table "H" or DIN-ND16.
(b) 2 ½" Flanged inlet suitable for ANSI - 150 Lbs, BS 4504 - Pn16, BS - 10 Table "H" or DIN-ND16
Blank Cap and Chain fitted as standard.



Pressure Restricting Valve

Item Code # NFF-LV-PRT

- ◆ Designed to reduce excess line Pressure.
- ◆ Simple and can be used a stand-alone pressure restricting device
- ◆ The opening of the Valve is Controlled which restricts the volume of water and thereby lowers the pressure of water
- ◆ Valves are similar to Standard Landing valves but with a specially designed mechanism incorporated into the stem and bonnet to limit how far the valve can be opened. The valve design has no ability to reduce outlet pressure under no-flow conditions.
- ◆ If low supply pressure conditions should arise the adjustable gauge stem can be overridden by removal of stop pin that would allow full opening of the valve and unrestricted flow of water.
- ◆ Unlike pressure regulating type valves, pressure restricting valves have no effect on the static pressure of a system.
- ◆ Gunmetal Construction for Corrosion Resistance and Sea Water Application
- ◆ Available in Valve Size 1.5 Inches and 2.5 Inches
- ◆ Inlet – Flanged or Threaded
- ◆ Outlet – Threaded / British Standard Instantaneous / Russian Gost / Storz



2 Way Inlet Breeching



- ◆ Body : Gun Metal or Aluminum Alloy or Cast Iron
- ◆ Inlet : Two Instantaneous with NRV
- ◆ Outlet : 4" Flanged
- ◆ Working Pressure : 10 Bar
- ◆ Test Pressure : 23 Bar

Item Code	Description
NFF-DRE-2W	Two way inlet Breeching made in Gun Metal
	Two way inlet Breeching made in Aluminum Alloy
	Two way inlet Breeching made in SGI / CI

3 Way Inlet Breeching



- ◆ Body : Gun Metal or Aluminum Alloy or Cast Iron
- ◆ Inlet : Three Instantaneous with NRV
- ◆ Outlet : 6" Flanged
- ◆ Working Pressure : 10 Bar
- ◆ Test Pressure : 23 Bar

Item Code	Description
NFF-DRE-3W	Three way inlet Breeching made in Gun Metal
	Three way inlet Breeching made in Aluminum Alloy
	Three way inlet Breeching made in SGI / CI

4 Way Inlet Breeching



- ◆ Body : Gun Metal or Aluminum Alloy or Cast Iron
- ◆ Inlet : Four Instantaneous with NRV
- ◆ Outlet : 6" Flanged
- ◆ Working Pressure : 10 Bar
- ◆ Test Pressure : 23 Bar

Item Code	Description
NFF-DRE-4W	Four way inlet Breeching made in Gun Metal
	Four way inlet Breeching made in Aluminum Alloy
	Four way inlet Breeching made in SGI / CI

Air Release Valve



- ◆ Body : Copper Alloy
- ◆ Inlet Connection : Threaded male Connection

Item Code	Description
NFF-DRE-ARV	Inlet Connection with 3/4" BSP
	Inlet Connection with 1" BSP

200 PSI - OS & Y Type Flanged End Gate Valve

Technical Specifications

- ◆ Design Standard: AWWA C515
- ◆ Norminal Pressure: 200 PSI
- ◆ Flange Standard: ANSI B16.1 Class 125 or according to the customer's requirements
- ◆ Both inside and outside of the body need Epoxy Resin Coating

Available Sizes

Size	2"	2 1/2"	3"	4"	5"	6"	8"	10"	12"



Model No.: NI-GVO-200FF

200 PSI - OS & Y Type Flanged End Gate Valve

Technical Specifications

- ◆ Design Standard: AWWA C515
- ◆ Norminal Pressure: 200 PSI
- ◆ Flange Standard: ANSI B16.1 Class 125 or according to the customer's requirements
- ◆ Groove Standard: Metric or AWWA C606
- ◆ Both inside and outside of the body need Epoxy Resin Coating

Available Sizes

Size	2"	2 1/2"	3"	4"	5"	6"	8"	10"	12"



Model No.: NI-GVO-200FG

200 PSI - OS & Y Type Grooved End Gate Valve

Technical Specifications

- ◆ Design Standard: AWWA C515
- ◆ Norminal Pressure: 200 PSI
- ◆ Groove Standard: Metric or AWWA C606
- ◆ Both inside and outside of the body need Epoxy Resin Coating

Available Sizes

Size	2"	2 1/2"	3"	4"	5"	6"	8"	10"	12"



Model No.: NI-GVO-200GG

200 PSI NRS Type Flanged End Gate Valve with Round Plate

Technical Specifications

- ◆ Design Standard: AWWA C515
- ◆ Nominal Pressure: 200 PSI
- ◆ Flange Standard: ANSI B16.1 Class 125 or according to the customer's requirements
- ◆ Both inside and outside of the body need Epoxy Resin Coating
- ◆ It could also be operated by the handwheel

Available Sizes

Size	2 1/2"	3"	4"	5"	6"	8"	10"	12"



Model No.: NI-GVN-200FF

200 PSI - NRS Type Grooved Gate Valve



Model No.: NI-GVO-200FG

Technical Specifications

- ◆ Design Standard: AWWA C515
- ◆ Nominal Pressure: 200 PSI
- ◆ Flange Standard: ANSI B 16.1 Class 125 or according to the customer's requirements
- ◆ Groove Standard: Metric or AWWA C606
- ◆ Both inside and outside of the body need Epoxy Resin Coating
- ◆ It could also be operated by the handwheel

Available Sizes

Size	2 1/2"	3"	4"	5"	6"	8"	10"	12"

200 PSI NRS Type Grooved End Gate Valve

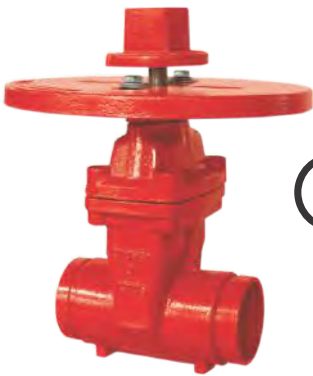

Model No.: NI-GVN-200GG

Technical Specifications

- ◆ Design Standard: AWWA C515
- ◆ Nominal Pressure: 200 PSI
- ◆ Groove Standard: Metric or AWWA C606
- ◆ Both inside and outside of the body need Epoxy Resin Coating
- ◆ It could also be operated by the handwheel

Available Sizes

Size	2 1/2"	3"	4"	5"	6"	8"	10"	12"

300 PSI - OS & Y Type Flanged End Gate Valve



Model No.: NI-GVO-300FF

Technical Specifications

- ◆ Design Standard: AWWA C515
- ◆ Nominal Pressure: 300 PSI
- ◆ Flange Standard: ANSI B 16.1 Class 125 or according to the customer's requirements
- ◆ Both inside and outside of the body need Epoxy Resin Coating

Available Sizes

Size	2 1/2"	3"	4"	5"	6"	8"	10"	12"

300 PSI NRS Type Flanged End Gate Valve



Model No.: NI-GVN-300FF

Technical Specifications

- ◆ Design Standard: AWWA C515
- ◆ Nominal Pressure: 300 PSI
- ◆ Flange Standard: ANSI B16.1 Class 125 or according to the customer's requirements
- ◆ Both inside and outside of the body need Epoxy Resin Coating
- ◆ It could also be operated by the handwheel

Available Sizes

Size	2 1/2"	3"	4"	5"	6"	8"	10"	12"

Water Type Butterfly Valve - UL Listed

Model No.: NI-BVW

- Working Pressure: 300 PSI (21 Bars)
- Working Temp: -20 °C ~ 110 °C (-4 °F ~ 230 °F)



Carried Standard	
Design Standard	API609
Face to Face Standard	ASME B16.1
Top Standard	ISO 5211
Test Standard	UL Listed

Available Sizes

Size	2 1/2"	3"	4"	5"	6"	8"	10"	12"

Grooved Type Butterfly Valve - UL Listed

Model No.: NI-BVG

- Working Pressure: 300 PSI (21 Bars)
- Working Temp: -20 °C ~ 110 °C (-4 °F ~ 230 °F)

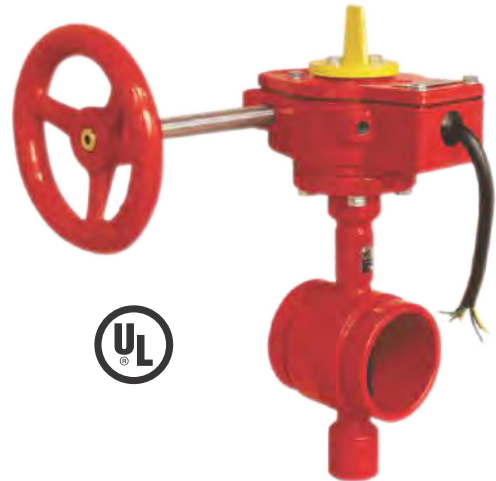

Carried Standard	
Design Standard	API609
Groove Standard	ANSI / AWWA C606
Top Standard	ISO 5211
Test Standard	UL Listed

Available Sizes

Size	2 1/2"	3"	4"	5"	6"	8"	10"	12"



- ◆ Suitable for storing 7.5 Mtr. or 15 Mtr. Single Hose
- ◆ 24" x 24" x 10"
- ◆ Lightweight
- ◆ Weatherproof
- ◆ Wall Mounted with M.S. Stand
- ◆ Finished with P.O. Red Color or Natural

Item Code # NFF-CB-HC-A

Item Code	Description
NFF-CB-HC-A	Made in FRP with Wall Mounting Type
	Made in FRP with Self Standing Type
	Made in 18 SWG CRCA Sheet with Wall Mounting Type
	Made in 18 SWG CRCA Sheet with Self Standing Mounting Type



- ◆ Suitable for storing two nos 7.5 mtr. or 15 mtr. hoses and one Nozzle
- ◆ M.S. Hose Box - 24" x 24" x 10" / 30" x 24" x 10" / 32" x 24" x 10"
- ◆ FRP Hose Box - 30" x 24" x 10" / 32" x 24" x 10"
- ◆ Lightweight
- ◆ Weatherproof
- ◆ Wall Mounted with M.S. Stand
- ◆ Finished with P.O. Red Color

Item Code # NFF-CB-HC-B

Item Code	Description
NFF-CB-HC-B	Made in FRP with Wall Mounting Type
	Made in FRP with Self Standing Type
	Made in 18 SWG CRCA Sheet with Wall Mounting Type
	Made in 18 SWG CRCA Sheet with Self Standing Mounting Type



- ◆ Suitable for storing two nos 25 mtr. or 30 mtr. hoses and one Nozzle
- ◆ 46" x 32" x 10"
- ◆ Lightweight
- ◆ Weatherproof
- ◆ Wall Mounted or Self-Standing (M.S. and S.S. Stand) Type
- ◆ Finished with P.O. Red Color

Item Code # NFF-CB-HC-C

Item Code	Description
NFF-CB-HC-C	Made in FRP with Wall Mounting Type
	Made in FRP with Self Standing Type
	Made in 18 SWG CRCA Sheet with Wall Mounting Type
	Made in 18 SWG CRCA Sheet with Self Standing Mounting Type

Foam Satiation Cabinet

- ◆ 2 nos 2 ½" × 30 mtr fire hose with Aluminium coupling
- ◆ 150 ltr FRP foam tank
- ◆ 2 ½" BSP threaded inlet
- ◆ One Low expansion branch pipe of 60 GPM capacity
- ◆ 60 GPM @ 100 PSI Foam Inductor adjustable 3% to 6%
- ◆ S.S. pick up tube
- ◆ Cabinet made for 1.6mm CRCA sheet
- ◆ Finished by P.O. Red color

Item Code # NFF-CB-FSC



Hose Reel Cabinet

- ◆ Wall Mounting Type
- ◆ For Swinging Hose Reel & Fixed Hose Reel
- ◆ Made Out From 1.6mm CRCA Sheet
- ◆ 27 ½" × 31 ½" × 15 ½" / 29" × 41" × 16"
- ◆ Threaded Inlet
- ◆ Finished by P.O. Red Color

Item Code # NFF-CB-HRC



Hose Rack Assembly

- ◆ Available in Two Sizes
- ◆ Available in Two Types of Mounting
- ◆ Complete with Hose Rack Assembly, 30 Mtr. Hose, Nozzle and Landing Valve and Nozzle
- ◆ Fixed or Swinging

Item Code	Description
NFF-CB-HRA	Hose Rack Assembly for 1 ½" Hose, Right Angle Valve Mounting
	Hose Rack Assembly for 2 ½" Hose, Right Angle Valve Mounting
	Hose Rack Assembly for 1 ½" Hose, with Wall Mounting Bracket and without Landing Valve
	Hose Rack Assembly for 2 ½" Hose, with Wall Mounting Bracket and without Landing Valve



Fixed Type Hose Reel



- ◆ Corrosion-free Water Ways
- ◆ Red Powder Coated Finishing
- ◆ Compact space design
- ◆ Available Hose – Rubber / Thermoplastic / PVC
- ◆ Operating Pressure – 12 Bar

Item Code	Hose Reel Material	Hose Diameter	Hose Length	Shut Off Nozzle
NFF-HR-FT	Galvanized Steel	¾"	30 m.	PVC
	Stainless Steel Gr. 304	1"	36 m.	
			40 m.	
			45 m.	
Stainless Steel Gr. 316	1 ½"			

Swinging Type Hose Reel



- ◆ Designed and Constructed in conformance to IS 884
- ◆ Aluminum Alloy Corrosion-free Water Ways
- ◆ Red Powder Coated Finishing
- ◆ Compact space design
- ◆ Manual swing type with 180° swivel
- ◆ Available Hose – Rubber / Thermoplastic / PVC
- ◆ Operating Pressure – 12 Bar

Item Code	Hose Reel Material	Hose Diameter	Hose Length	Shut Off Nozzle
NFF-HR-ST	Galvanized Steel	¾"	30 m.	PVC
	Stainless Steel Gr. 304	1"	36 m.	
			40 m.	
			45 m.	
Stainless Steel Gr. 316	1 ½"			

Stand Mounting Hose Reel



- ◆ Material – Galvanized Steel / Stainless Steel Gr. 304 / Stainless Steel Gr. 316
- ◆ Threaded / Flanged Inlet Connection
- ◆ Waterway made up from Corrosion Free Material
- ◆ Red Powder Coated Finishing
- ◆ Pedestal Bearing ensures smooth Rotational function
- ◆ Available Hose – Rubber / Thermoplastic / PVC
- ◆ Operating Pressure – 12 Bar

Item Code	Hose Reel Material	Hose Diameter	Hose Length	Jet Cum Spray Nozzle		
NFF-HR-SM	Galvanized Steel	¾"	30 m.	Gunmetal Aluminium Alloy		
			36 m.			
	Stainless Steel Gr. 304	1"	40 m.			
			Stainless Steel Gr. 316		1 ½"	45 m.
						60 m.



Hose Reel With Foam Station

- ◆ Complete with Foam tank, Foam Inductor, Hose reel with nozzle Threaded / Flanged Inlet Connection
- ◆ Pedestal Bearing ensures smooth rotating action
- ◆ 225 Liter foam tank. Other sizes available on request
- ◆ Inline inductor 0 to 6% & Jet-Spray nozzle
- ◆ Waterways made from Stainless Steel & Gun Metal Recommended Hose – Rubber Braided Hose
- ◆ Detachable Rewinding Handle Red Powder Coated Finishing
- ◆ Operating pressure – 12 Bar



Item Code	Hose Reel Material	Hose Diameter	Hose Length	Jet Cum Spray Nozzle
NFF-HR-FS	Galvanized Steel	¾"	30 m.	Gunmetal Aluminium Alloy
	Stainless Steel Gr. 304	1"	36 m.	
			40 m.	
	Stainless Steel Gr. 316	1 ½"	45 m.	
			60 m.	

PVC Hose Reel Nozzle

- ◆ Jet Spray Type
- ◆ Strong and Corrosion Free
- ◆ Serrated end for hose fitting
- ◆ 16 GPM @100 PSI



Item Code	Description
NFF-HR-NZ-PVC	With ¾" serrated End
	With 1" serrated End

Gunmetal Hose Reel Nozzle

- ◆ Construction in Gunmetal as BS1400
- ◆ Jet spray & shut off type
- ◆ Chrome plated finish (Optional)
- ◆ Also available in Stainless Steel Gr. 304

Item Code	Description
NFF-HR-NZ-GM	With ¾" serrated End
	With 1" serrated End

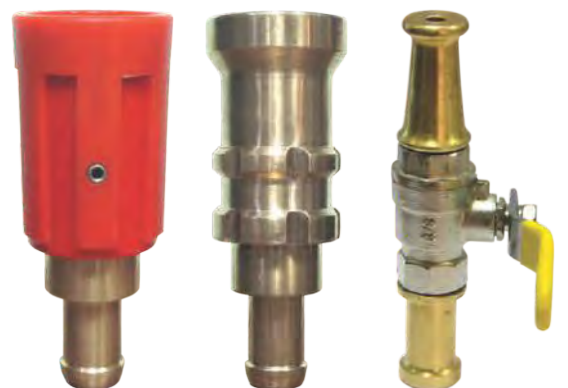



- ◆ Made up of High quality PVC Polymer
- ◆ Light in weight and Durable

Item Code	Hose Diameter	Hose Length	Hose Colour
NFF-HR-H-PVC	3/4" 1"	30 m.	Red
		36 m.	
		40 m.	Black

Rubber Hose



- ◆ High pressure braided rubber hose as per IS: 444 Type I, Type II & Type III
- ◆ For water delivery purpose in Railways, Industries, Dams, Mines, Horticulture, Irrigation, Fire fighting, Construction Sites, Car Washing, De-watering etc.

Item Code	Hose Diameter	Hose Length	Hose Colour
NFF-HR-H-R	3/4" 1" 1 1/2"	30 m.	Red
		36 m.	
		40 m.	Black
		45 m.	

Thermoplastic Hose



- ◆ Made up of Special grade Thermoplastic Hybrid Compound
- ◆ Light Weight, High Pressure, Flame Resistant, Long Shelf Life

Item Code	Hose Diameter	Hose Length	Hose Colour
NFF-HR-H-TP	3/4" 1"	30 m.	Red
		36 m.	
		40 m.	Black

One Way Standpost

- ◆ Body : Carbon Steel
- ◆ Inlet : 4" Flanged
- ◆ Outlet : 1 nos of 2 1/2" Flanged
- ◆ Working Pressure : 150 PSI
- ◆ Test Pressure : 325 PSI

Item Code	Description
NFF-SPH-OW	Made up of Carbon Steel having 4" Flanged Inlet and 2 1/2" Flanged Outlet



Two Way Standpost

- ◆ Body : Carbon Steel
- ◆ Inlet : 4" / 6" Flanged
- ◆ Outlet : 2 nos of 3" Flanged
Optional, 1 Nos. of 4" Flanged Outlet for Monitor
- ◆ Working Pressure : 150 PSI
- ◆ Test Pressure : 325 PSI

Also available with Pumper Connection & Landing Valves

Item Code	Description
NFF-SPH-TW	Made up of Carbon Steel having 4" Flanged. Pumper connection & Valve available



Four Way Standpost

- ◆ Body : Carbon Steel
- ◆ Inlet : 6" Flanged
- ◆ Outlet : 4 nos of 2 1/2" Flanged
- ◆ Working Pressure : 150 PSI
- ◆ Test Pressure : 325 PSI

Also available with Pumper Connection & Landing Valves

Item Code	Description
NFF-SPH-4W	Made up of Carbon Steel having 6" flanged inlets and 4 Nos. flanged outlets Optionally, With Pumper connection & Valve

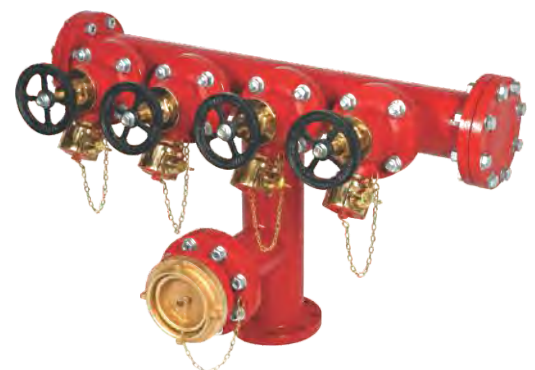

Four Way Standpost (Cross Arm Type)



- ◆ Body : Carbon Steel / Cast Iron
- ◆ Inlet : 6" Flanged
- ◆ Outlet : 4 nos of 2.5" Threaded / 2.5" Flanged
- ◆ Working Pressure : 150 PSI
- ◆ Test Pressure : 325 PSI
- ◆ Landing Valve (Optional) : 2.5" Threaded / Flanged Landing Valve with BS 336 Female Instantaneous Outlet

Item Code	Description
NFF-SPH-4WCA	Made up of Carbon Steel having 6" flanged inlets and 4 Nos. flanged outlets Optionally, With Pumper connection & Valve

Dry Barrel Pillar Hydrant



Dry Barrel Pillar Hydrant is operated by using a hydrant wrench to turn the operating mechanism at the top of the hydrant. Available in 4" size.

- ◆ Body : Cast Iron
- ◆ Valve Seat : Neoprene Rubber
- ◆ Valve Seat Ring : Gunmetal
- ◆ Outlet : 2 nos of 2 1/2" Gunmetal Female Instantaneous & 1 Nos. of 4" Pumper Connection
- ◆ Working Pressure : 150 PSI
- ◆ Test Pressure : 325 PSI

Item Code	Description
NFF-SPH-DB	Made up of Cast Iron Casting having 2 x 2 1/2" Female instantaneous Outlet & 1 x 4" Pumper Connection

Single Standpipe

- ◆ Body : Aluminum
- ◆ Inlet : Threaded BSRT / (F) Inst.
- ◆ Outlet : Female Instantaneous as per BS 336
- ◆ Working Pressure : 150 PSI
- ◆ Body Test : 325 PSI

Item Code	Description
NFF-SPH-SP	Aluminum body with Single outlet



Double Standpipe

- ◆ Body : Aluminum
- ◆ Inlet : Threaded BSRT / (F) Inst.
- ◆ Outlet : Female Instantaneous as per BS 336
- ◆ Working Pressure : 150 PSI
- ◆ Body Test : 325 PSI

Item Code	Description
NFF-SPH-SP	Aluminum body with Double outlet



Underground Fire Hydrant & Key



- ◆ Body : Grey Cast Iron
- ◆ Inlet : Flanged
- ◆ Outlet : Gun Metal Threaded Outlet
- ◆ Working Pressure : 150 PSI
- ◆ Seat Test : 240 PSI
- ◆ Body Test : 325 PSI

Item Code	Description
NFF-SPH-UG	Outlet as 2 1/2" BSRT Male
	Outlet as 2 1/2" Inst. Male

- ◆ MS / Aluminum
- ◆ Used for operation of Under Ground Hydrant

Item Code	Description
NFF-SPH-HK	Made in Steel / Aluminum Alloy

Duck Foot Band



- ◆ Body - Grey Cast Iron to BS 1452
- ◆ Flanged Inlet and Outlet - 4" BS Table 10 E Flange

Surface Box



- ◆ Cast Iron
- ◆ Length 15" x width 9" x Height 5"

Item Code	Description
NFF-SPH-SB	Made in SGI

Short Branch Pipe

- ◆ Type – Solid Jet Nozzle
- ◆ Material – Gunmetal / Aluminum Alloy / Stainless Steel
- ◆ Operating Pressure – 10 bar
- ◆ Finish – Natural Polish

Item Code # NFF-BP-SB

Nozzle Tip Size	Available Material of Construction	Available Inlet Size
15mm	Gunmetal	2.5" Male Inst
20mm	Aluminum Alloy	2.5" BSP / NPT / NH Threads
25mm	Stainless Steel	2.5" Storz



Long Branch Pipe

- ◆ Type – Solid Jet Nozzle
- ◆ Material – Gunmetal / Aluminum Alloy / Stainless Steel
- ◆ Operating Pressure – 10 bar
- ◆ Finish – Natural Polish

Item Code # NFF-BP-LB

Nozzle Tip Size	Available Material of Construction	Available Inlet Size
15mm	Gunmetal	2.5" Male Inst
20mm	Aluminum Alloy	2.5" BSP / NPT / NH Threads
25mm	Stainless Steel	2.5" Storz



Triple Purpose

- ◆ Type – Jet - Spray - Shut Off Nozzle
- ◆ Material – Gunmetal / Aluminum Alloy / Stainless Steel
- ◆ Operating Pressure – 10 bar
- ◆ Finish – Natural Polish / Chrome Plated

Item Code # NFF-BP-TP

Flow (LPM)	Available Material of Construction	Available Inlet Size
600 LPM	Gunmetal	2.5" Male Inst
900 LPM	Aluminum Alloy	2.5" BSP / NPT / NH Threads
	Stainless Steel	2.5" Storz





- ◆ Type – Jet - Spray - Shut Off Nozzle
- ◆ Material – Gunmetal / Aluminum Alloy / Stainless Steel
- ◆ Operating Pressure – 10 bar
- ◆ Finish – Natural Polish / Chrome Plated

Item Code # NFF-BP-ND

Flow (LPM) @ 7 Bar	Available Material of Construction	Available Inlet Size
400 LPM	Gunmetal	2.5" Male Inst 2.5" BSP / NPT / NH Threads
	Aluminum Alloy	
	Stainless Steel	

Navy Diffuser MINI



- ◆ Type – Jet - Spray - Shut Off Nozzle
- ◆ Material – Aluminum Alloy / Stainless Steel
- ◆ Operating Pressure – 10 bar
- ◆ Finish – Natural Polish / Hard Anodized

Item Code # NFF-BP-NDM

Flow (LPM) @ 7 Bar	Available Material of Construction	Available Inlet Size
300 LPM	Aluminum Alloy	2.5" Male Inst 2.5" BSP / NPT / NH Threads
	Stainless Steel	

Hand Controlled Jet & Spray



- ◆ Type – Jet – Spray - Shutoff Nozzle
- ◆ Material – Aluminum Alloy / PVC
- ◆ Operating Pressure – 10 bar
- ◆ Finish – Natural Finish

Item Code # NFF-BP-HCA / NFF-BP-HCB

Flow (LPM) @ 7 Bar	Type	Material of Construction	Available Inlet Size
150 LPM	Jet - Spray - Shut Off	Aluminum Alloy with	2.5" Male Inst
450 LPM	Jet - Spray - Shut Off with Water Curtain	PVC Nozzle tip and body	2.5" BSP / NPT / NH Threads

Jumbo Curtain Nozzle

- ◆ Type – 180 Degree Curtain Nozzle
- ◆ Material – Gunmetal / Stainless Steel
- ◆ Operating Pressure – 10 bar
- ◆ Finish – Natural Finish / Painted



Item Code # NFF-BP-JC

Flow (LPM) @ 7 Bar	Type	Material of Construction	Available Inlet Size
750 to 6000 LPM	Curtain Nozzle with Handle	Gunmetal	2.5" Male Inst
	Curtain Nozzle without Handle	Stainless Steel	2.5" BSP / NPT / NH Threads Flange Inlet

3 Position Nozzle

- ◆ Type – Jet Spray and Shutoff
- ◆ Material – Gunmetal / PVC
- ◆ Operating Pressure – 10 bar
- ◆ Finish – Chrome Plated / PVC

Item Code # NFF-BP-3P

Bore Size	Spray Flow (LPM) @ 7 Bar	Jet Flow (LPM) @ 7 Bar	Material of Construction	Available Inlet Size
12	345	255	Chrome Plated	2.5" Male Inst
16	570	450	Gunmetal	2.5" BSP / NPT / NH Threads
20	855	705	PVC	Flange Inlet



Combat Nozzle

- ◆ Lightweight with spinning teeth ring for wide fog curtain
- ◆ Molded rubber grip for firm hold
- ◆ Type – Hollow Jet, Spray and Shutoff
- ◆ Operating Pressure – 10 bar

Item Code # NFF-BP-CM

Flow (LPM)	Material of Construction	Available Inlet Size
350 LPM	Aluminum Alloy	2.5" Male Inst
		2.5" BSP / NPT / NH Threads
		Swivel Inlet





- ◆ Type – Jet and Fog
- ◆ Material – Gunmetal
- ◆ Operating Pressure – 10 bar
- ◆ Finish – Natural Polish
- ◆ As per IS:952

Item Code # NFF-BP-FG

Fog Flow (LPM) @ 7 Bar	Jet Flow (LPM) @ 7 Bar	Material of Construction	Available Inlets
225 LPM	400 LPM	Gunmetal	2.5" Male Inst 2.5" BSP / NPT / NH Threads

Revolving Branch Pipe



- ◆ Type – Revolving Nozzle
- ◆ Material – Gunmetal
- ◆ Operating Pressure – 10 bar
- ◆ As per IS:906

Item Code # NFF-BP-RB

Fog Flow (LPM) @ 7 Bar	Material of Construction	Available Inlets
250 to 900 LPM	Gunmetal	2.5" Male Inst 2.5" BSP / NPT / NH Threads 2.5" / 3" NB Flanged Inlet as per ANSI

Portable Spray Nozzle UL Listed



- ◆ The UL Listed portable spray nozzle is fabricated and tested in accordance with UL-401. The nozzle is intended for use with lined fire hose mounted on standpipe systems.
- ◆ The nozzle is rated for use at an inlet pressure of 100 PSI. The nozzle has rotational type control. It is an adjustable type having a water spray discharge ranging from a wide cone shaped pattern through straight stream to shut-off.
- ◆ The nozzle is intended to be used on class A and B fires only, and the discharge rate at 100 PSI flowing inlet pressure in full spray pattern 1.5" nozzle is 130 GPM (approx.) and for 2.5" nozzle is 205 GPM approx.
- ◆ These nozzles come with NST (NH) female inlet threads in accordance with ANSI B2.4.

Constant Gallonage Jet & Spray - Neulite

- ◆ Light Alloy hard anodized construction
- ◆ Straight Stream to wide fog
- ◆ Pressure assisted flush without shut-off
- ◆ Delrin ball shut-off handle to work smoothly at extreme range
- ◆ Wide fog for operator protection
- ◆ Anti-slip pistol type finger lock grip
- ◆ Control Lever for ON-OFF



Item Code # NFF-NZ-NLT

Flow Capacity	Working Pressure	Spray Angle	Inlets
450 LPM	7 Bar	160 Degree	1.5"/2.5" Male Instantaneous 1.5"/2.5" BSP/NST/NH threads Other Inlets available on request
900 LPM	7 Bar	160 Degree	

Automatic Nozzle - Fast Action Junior

- ◆ Automatic Pressure Control
- ◆ Specially designed to give low back pressure
- ◆ Durable light hard anodized aluminum alloy construction
- ◆ Sliding valves allow turbulence free flow
- ◆ Straight stream to wide fog and flush without shut-off
- ◆ Molded rubber bumper with flexible fog teeth creates thick fog pattern
- ◆ Pistol grip handle designed for greater comfort and control to fire



Item Code # NFF-NZ-FANJ

Flow Capacity	Working Pressure	Bore Dia	Inlets
35 / 475 LPM	7 Bar	1.5"	1.5"/2.5" Male Instantaneous 1.5"/2.5" BSP/NST/NH threads Other Inlets available on request

Pistol Grip Nozzle



Automatic Dual Pressure Nozzle - Fast Action



- ◆ Specially designed Dual Pressure Nozzle
- ◆ At emergency mode (at low pressure), Nozzle maintains same performance
- ◆ Durable light hard anodized construction
- ◆ Sliding valves allow turbulence free flow
- ◆ Straight stream to wide fog and flush without shut-off
- ◆ Molded rubber bumper with flexible fog teeth creates thick fog pattern
- ◆ Pistol grip handle designed for greater comfort and control to fire
- ◆ 1/5"/2.5" male instantaneous / Storz / BSP or NH or NST threaded inlets available

Item Code # NFF-NZ-FAN

Nozzle Pressure	4 Bar		5 Bar		7 Bar		8 Bar	
Operating Mode	Standerd	Emergency	Standerd	Emergency	Standerd	Emergency	Standerd	Emergency
Flow Rate LPM	280	550	350	675	700	850	800	960
Spray Angle Degree	160	160	160	160	160	160	160	160

Multipurpose Combination Flow - Aquajet



- ◆ Solid Jet and Fog facility simultaneously or independently
- ◆ Specialdesign gives low back Pressure
- ◆ Durable light hard anodized construction
- ◆ Straight Stream to Dense fog & flush without shut off
- ◆ Ball Valve for flow control
- ◆ Anti-Slop rubber molded pistol grip
- ◆ 1/5"/2.5" male instantaneous / Storz / BSP or NH or NST threaded inlets available
- ◆ NFPA 1964 compliant

Item Code # NFF-NZ-AQ

Bore (mm)	Pressure (Bar)	Solid Jet Flow (LPM)	Fog Flow (LPM)	Jet + Fog Flow (LPM)	Inlets
16	5.25	350	300	650	.5" / 2.5" Male Instantaneous 1.5" / 2.5" BSP / NST / NH threads Other Inlets available on request
19	5.25	500	300	800	
25	5.25	860	300	1160	

Selectable Gallonage - Superfire

- ◆ Special design gives low back pressure
- ◆ Constant Selectable gallon age Nozzle with multiple flow setting
- ◆ Flow remains the same in all pattern
- ◆ Durable light hard anodized construction
- ◆ Straight stream to dense fog & flush without shut off
- ◆ Ball valve for flow control
- ◆ Anti-Slip rubber molded pistol grip
- ◆ Female inlet with instantaneous male Coupling, NH or NPSH threads
- ◆ NFPA 1964 compliant

Item Code # NFF-NZ-SPF & NFF-NZ-SPFJ

Bore Dia	Working Pressure	Flow Rate (LPM)	Inlets
1.5"	7 Bar	115-230-360-475	1.5"/2.5" Male Instantaneous 1.5" / 2.5" BSP / NST / NH threads Other Inlets available on request
1.5"	7 Bar	360-475-565-755-950	



High Pressure Nozzle - Challenger

- ◆ Designed for high pressure application up to 40 bar
- ◆ Constant selectable Gallonage Nozzle with multiple flow setting
- ◆ Durable light hard anodized construction
- ◆ Straight stream to Dense fog & flush without shut off
- ◆ Ball valve for flow control
- ◆ Unbreakable stainless steel spinning teeth
- ◆ Anti-Slip rubber molded pistol grip
- ◆ Meets the need of forestry and municipal application where water conservation is desired

Item Code # NFF-NZ-CH

Bore Dia	Working Pressure	Flow Rate (LPM)	Inlets
1"	40 Bar	50 - 95 - 150 - 225	1.5"/2.5" Male Instantaneous 1.5" / 2.5" BSP / NST / NH threads Other Inlets available on request



Foam Tubes For Nozzle

- ◆ Designed to quickly attach to bumper of Nozzle
- ◆ Can be used with all types of foams
- ◆ Enhances the expansion of foam solution and delivers longer reach and heavier foam blanket
- ◆ Available in 14" and 16" sizes

Item Code # NFF-NZ-CH



Water Spray Nozzle



Medium Velocity Spray Nozzle



Description	Inlet	K Factor	Spray Angle Degree	Material of Construction	Finish
1/2" Size	BSP / NPT / NH Threads	24 / 28 / 31 / 36 / 41 / 45 / 51 / 57 /	60 / 75 / 80 / 90 / 100 / 110 / 120 / 140 / 180	Forged Brass Stainless Steel	Natural Chrome Finish
3/4" Size		61 / 66 / 71 / 76 / 81 / 86 / 91			

High Velocity Spray Nozzle



Description	Inlet	K Factor	Spray Angle Degree	Material of Construction	Finish
1/2" Size	BSP / NPT / NH Threads	18 25	75 80	Forged Brass Stainless Steel	Natural Chrome Finish
3/4" Size		32 47	85 90		

Tank Cooling Nozzle



Description	Inlet	K Factor	Material of Construction	Finish
1/2" Size	BSP / NPT / NH Threads	20 / 30 / 37	Forged Brass Stainless Steel	Natural Chrome Finish
		45 / 53 / 72		

Pendent Type



- ◆ UL Listed
- ◆ Made Out of Bronze
- ◆ Maximum Working Pressure 175 PSI

Description	Inlet Connection	Finish
Rated Temp 68°	1/2" NPT	Natural Chrome Plated
Rated Temp 79°		

Upright Type

- ◆ UL Listed
- ◆ Made Out of Bronze
- ◆ Maximum Working Pressure 175 PSI

Description	Inlet Connection	Finish
Rated Temp 68°	½" NPT	Natural Chrome Plated
Rated Temp 79°		



Sidewall Type

- ◆ UL Listed
- ◆ Made Out of Bronze
- ◆ Maximum Working Pressure 175 PSI

Description	Inlet Connection	Finish
Rated Temp 68°	½" NPT	Natural Chrome Plated
Rated Temp 79°		



Flexible Hose

Length	700, 1000, 1200, 1500, 1800mm
Reducing Nipple Dia	½", ¾" NPT or BSPT (Straight or 90 Degree Elbow)
Type	Unbraided Braided (ø 26.8) Braided (ø 28.0)

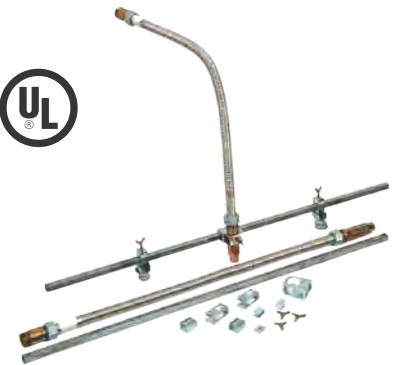

Alarm Valve

Dimension (mm)				
Model	Size	L	C	D
NEWAGE AV-4	4"	229	190.5	100
NEWAGE AV-6	6"	255	241.5	150

Technical Data

Water working pressure rating	75 psig (12.3 bar)
Factory hydrostatic test pressure	350 psig (24.6 bar)
US standard flange inlet and outlet mate	ANSI B16.5 (150 lb) flange
Approval	UL Listed



Low Expansion Foam Branch

I. FB2X / FB10X / FB20X



- ◆ Designed to perform well with all types of foam
- ◆ Designed for low expansion foam applications with expansion ratio of 1:2 to 1:12
- ◆ Standard version without inbuilt induction and pick-up tube for use with premix solution
- ◆ Inlet connections – BS 336 / BSP threads / GOST / Storz / American Rocker Lug
- ◆ Control Valve optionally available
- ◆ Available in Straight / Dome pattern

Item Code	Description	Flow @ 7 Bar	Material of Construction
NFF-FE-FB-2X	With In-Built Foam Inductor	225 LPM	Aluminum Alloy Stainless Steel
NFF-FE-FB-10X		450 LPM	
NFF-FE-FB-20X		900 LPM	

II. FB2 / FB10 / FB20



- ◆ Designed to perform well with all types of foam
- ◆ Designed for low expansion foam applications with expansion ratio of 1:2 to 1:12
- ◆ Self-inducing version with 3% or 6% fixed induction rate along with pick-up tube and dip pipe
- ◆ Inlet connections – BS 336 / BSP threads / GOST / Storz / American Rocker Lug
- ◆ Control Valve optionally available
- ◆ Available in Straight / Dome pattern

Item Code	Description	Flow @ 7 Bar	Material of Construction
NFF-FE-FB-2	With In-Built Foam Inductor	225 LPM	Aluminum Alloy Stainless Steel
NFF-FE-FB-10		450 LPM	
NFF-FE-FB-20		900 LPM	

III. FB5X



Item Code # NFF-FE-FB5X

- ◆ Low expansion foam branch with 225 LPM flow at 7 bar with expansion ratio of 1:2 to 1:10
- ◆ With in-built foam inductor along with pick-up tube and dip pipe
- ◆ Built-in foam proportioning valve from 0 to 6% induction
- ◆ Built-in shut off valve

Inline Foam Generator

- ◆ Inline Foam Generator is modified version of Inline Inductor, which not only inducts the foam in desired concentration 3% or 6%, but also transports the foam a long distance (approx. 60 mtrs)
- ◆ Inlet – British Standard Instantaneous Couplings
- ◆ Outlet – British Standard Instantaneous Coupling
- ◆ Induction – 3 % or 6 %



Item Code	Flow @ 7 Bar	Material of Construction
NFF-FE-FGI	225 LPM	Aluminum Alloy
	450 LPM	Gunmetal

Medium Expansion Foam Generator

Item Code # NFF-FE-MEFG

Self aspirating

Designed for fire protection and vapor suppression in bunded or dyked areas

Suitable for applications that required free flowing expanded foam in large volumes

Compatible with all types of foam

- ◆ Foam expansion ratio of 1:20 to 1:50
- ◆ Stainless steel construction
- ◆ Inlet connection – Flanged or British Standard Instantaneous
- ◆ Foam Generator consists of set of Inline Inductor and Foam Branch
- ◆ Inline Inductor with flanged or coupling ends with built-in check valve, pickup tube and foam isolation valve
- ◆ Flow capacity 400 LPM and 600 LPM
- ◆ Operating pressure range – 2.5 to 7 bar
- ◆ Foam branch – 3.5 to 4 bar
- ◆ Inline Inductor – 7 bar



HI-EX Mini Turbex



- ◆ Compact, Light Weight and capable of Single Handed Operation
- ◆ Suitable for all types of Foam
- ◆ Foam Expansion Ratio of 1:200 to 1:350
- ◆ Stainless Steel or FRP Casing
- ◆ Corrosion Proof Construction
- ◆ Pelton Wheel Turbine Driven
- ◆ Set consists of Inline Inductor and Foam Generator
- ◆ Foam Inductor 3 % or 6 %
- ◆ Can also be used as a Foam Extractor with optional Collapsible Ducting
- ◆ Nylon Net for Foam Expansion is standard accessory supplied with Foam Generator

Item Code	Flow @ 7 Bar	Foam Produced	Smoke Extracted
NFF-FE-MINI	245 LPM	2825 cubic ft/min	3460 cubic ft/min

HI-Expansion Foam Generator (MK II)



- ◆ FRP Casing for Corrosion free Mechanism
- ◆ Unit mounted on Wheel for easy Transportation
- ◆ Fan mounted on the shaft of Water Turbine
- ◆ Built-in Foam Induction System
- ◆ Foam Induction 3 % or 6 %
- ◆ Suitable for All types of Foam
- ◆ Foam Expansion Ratio of 1:400 to 1:1100
- ◆ Special By-pass Valve arrangement to control Back Pressure
- ◆ Can also be used as a Foam Extractor with optional Collapsible Ducting
- ◆ Nylon Net for Foam Expansion is standard accessory supplied with Foam Generator

Item Code	Description	Total Water Flow @ 7 Bar	By-Pass Flow @ 7 Bar	Expanded Foam	Expansion
NFF-FE-MK2	By-Pass Valve Closed	220 LPM	Nil	132 cubic m/min	500 to 750
	By-Pass Valve Open	230 LPM	85 LPM	145 cubic m/min	800 to 1100

Fixed Inductor

- ◆ For fixed installation systems
- ◆ With 3% to 6% foam induction
- ◆ Available in wide range of flow
- ◆ Carbon steel construction treated with anti-corrosive coating
- ◆ Flanged inlet and outlet connections as per ANSI
- ◆ Stainless steel construction also available

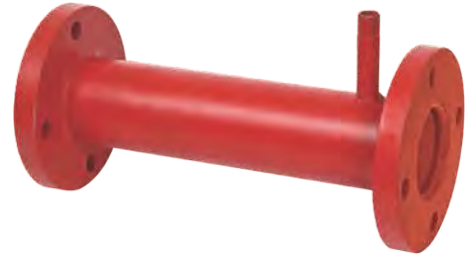

Item Code	Size of Inlet & Outlet	Flow Rate @ 7 Bar	End Connection
NFF-FE-FII	2"	75-225 LPM	Instantaneous as per BS 336
	2.5"	225-450 LPM	
	3"	450-900 LPM	
	4"	900-1800 LPM	Flanged as per ANSI
	6"	1800-2700 LPM	
	8"	2700-3600 LPM	

Variable Inline Inductor

- ◆ Foam induction rates can be adjusted from 0% to 6%
- ◆ In-built non-return valve to foam inlet
- ◆ Foam concentrate drawn through a pick-up tube
- ◆ Light in weight and portable
- ◆ Isolation valve optionally available



Item Code	Flow @ 7 Bar	Material of Construction
NFF-FE-VID	225 LPM	Aluminum Alloy Gunmetal Stainless Steel
	450 LPM	

Foam Maker Without Vapor Seal Chamber



- ◆ Designed for the use in Fixed Roof Tank with low expansion Foam System
- ◆ Air Aspirating Foam Chamber consists of Expansion Chamber and Foam Maker with Stainless Steel Mesh for Aeration and prevention of entering of Foreign objects
- ◆ Carbon Steel or Stainless Steel Construction
- ◆ Hot Dip Galvanised for Corrosion resistance in case of Carbon Steel Construction
- ◆ 5 Models available to cover all the Flow Requirements
- ◆ Glass Vapour Seal to prevent the entry of Vapour into the Chamber and thereby prevent the evaporation into atmosphere.
- ◆ Orifice Plate designed as per the required flow at a desired pressure is standard supply along with Foam Maker
- ◆ Orifice Plate can be changed in case of change in Design Parameters
- ◆ Inspection of Vapour Seal is simplified with the help of Handle on top of removable cover plate of Foam Chamber
- ◆ Foam Deflector for directing the Expanded Foam into Tank is optional accessory.

Item Code	Inlet (NB)	Outlet (NB)	Discharge
NFF-FE-FMWOVS	50	80	75-225 LPM
	65	100	225-450 LPM
	80	150	450-900 LPM
	100	200	900-1800 LPM
	150	250	1800-2700 LPM

Foam Maker With Vapor Seal Chamber



- ◆ Designed for the use in Floating Roof Tank with low expansion Foam System
- ◆ Air Aspirating Expanded Foam Discharge Device consisting Expansion Chamber and Foam Maker with Stainless Steel Mesh for Aeration and prevention of entering of Foreign objects
- ◆ Carbon Steel or Stainless Steel Construction
- ◆ Hot Dip Galvanized for Corrosion resistance in case of Carbon Steel Construction
- ◆ 5 Models available to cover all the Flow Requirements
- ◆ Orifice Plate designed as per the required flow at a desired pressure is standard supply along with Foam Maker
- ◆ Orifice Plate can be changed in case of change in Design Parameters
- ◆ Foam Poured for directing the Expanded Foam into Tank is optional accessory.

Item Code	Inlet (NB)	Outlet (NB)	Discharge
NFF-FE-FMWVS	50	80	75-225 LPM
	65	100	225-450 LPM
	80	150	450-900 LPM
	100	150	900-1800 LPM
	150	200	1800-2700 LPM

High Back Pressure Foam Maker



Item Code # NFF-FE-HBPFM

- ◆ Designed to generate expanded foam for the purpose of subsurface injection into a liquid hydrocarbon storage tank.
- ◆ High Back Pressure Foam Makers are mounted at the bottom of the Tank or outside the diked area surrounding the storage tank.
- ◆ Expanded foam is injected through a dedicated Foam line or into a Liquid Hydrocarbon line.
- ◆ Can discharge against a back pressure as high as 40% of the operating inlet pressure.
- ◆ High Back-Pressure Foam Maker is available with Self Induction Mechanism and another for the use with Premix Foam Solution
- ◆ Stainless Steel Screen Mesh for Aeration and prevention of entering of Foreign objects
- ◆ Aluminium Alloy Hard Anodized, Carbon Steel or Stainless Steel Construction
- ◆ Hot Dip Galvanised for Corrosion resistance in case of Carbon Steel Construction
- ◆ Custom Design based on required Flow Rate

FRP Tank Mobile Foam Unit

- ◆ Mobile Foam Cart with Corrosion Resistant FRP Tank
- ◆ Lightweight and Durable for use in rugged conditions
- ◆ First aid and Rapid Deployment in high risk areas
- ◆ Easy access in narrow passages where Fixed Piping or Fire Vehicle are inaccessible.
- ◆ Tank Mounted on a Steel Structure with 2 Solid Rubber Wheels for ease of mobility.
- ◆ Available with Tank Capacity of 100,150 and 200 Liters
- ◆ Aluminum Alloy Low Expansion Foam Branch 225 LPM or 450 LPM along with Corresponding 3 % or 6 % Fixed Inline Inductor made of Aluminum Alloy supplied as Standard Equipment
- ◆ Provision for Storage of 2 No of 15 Meters X 63 MM Type B Hose along with Couplings.
- ◆ Variable Inline Inductor, Medium Expansion Foam Generator and Fire Hoses are optionally supplied.

Item Code	Tank Capacity
NFF-FE-MFU-FRP	100 Liters
	150 Liters
	200 Liters



Stainless Steel Tank Mobile Foam Unit

- ◆ Mobile Foam Cart with Stainless Steel Tank
- ◆ Durable for use in rugged and Corrosive Environments like Chemical Plants, Onshore Platforms, Jetty.
- ◆ Available in Stainless Steel Grade 304, 316 and 316L
- ◆ First aid and Rapid Deployment in high risk areas
- ◆ Easy access in narrow Corridors and tight passages where Fixed Piping or Fire Vehicle are inaccessible.
- ◆ Tank Mounted on a Steel Structure with 2 Solid Rubber Wheels and 1 Rotating Castor for ease of Steering and Mobility.
- ◆ Available with Standard Tank Capacity of 100,150 and 200 Liters.
- ◆ Tank with customized Volumes available on Request
- ◆ Aluminum Alloy Low Expansion Foam Branch 225 LPM or 450 LPM along with Corresponding 3 % or 6 % Fixed Inline Inductor made of Aluminum Alloy supplied as Standard Equipment
- ◆ Provision for Storage of 2 No of 15 Meters X 63 MM Type B Hose along with Couplings.
- ◆ Variable Inline Inductor, Medium Expansion Foam Generator and Fire Hoses are optionally supplied.

Item Code	Tank Capacity
NFF-FE-MFU-SS	100 Liters
	150 Liters
	200 Liters



Fast Attack Mobile Foam Unit

- ◆ Mobile Foam Cart with Stainless Steel Tank and Water Foam Monitor
- ◆ Easy Operation by one person
- ◆ With Capabilities of more than of a Portable Monitor, Unit is used for First aid and Rapid Deployment in high risk areas
- ◆ Easy access in narrow Corridors and tight passages where Fixed Piping or Fire Vehicle are inaccessible.
- ◆ Ideal for Applications like Oil & Gas, Chemical Plants, Low Hazard Industries, Protection of Stationary Hazard, Protection of Remote Hazard Areas etc
- ◆ Carbon Steel or Gunmetal Monitor with Aqua Foam Nozzle with Jet-Fog Arrangement
- ◆ Monitor with Maximum Flow of 300 GPM at rated pressure of 100 PSI.
- ◆ 63 MM British Standard Instantaneous or Optional Threaded Inlet with choice of Russian, GOST or American Rocker Lug Coupling
- ◆ Tank available in Stainless Steel Grade 304, 316 and 316L with Standard Capacity of 200 Liters
- ◆ Tank equipped with Filling Cap, Air Vent and Drain Valve
- ◆ Unit is equipped with 2 Solid Rubber Wheels for Mobility and Heavy duty Stabilizers to prevent the unit from destabilizing under pressure.
- ◆ Handle Bars for easy maneuverability
- ◆ Provision for Storage of 1 No of 30 Meters X 63 MM Type B Hose along with Couplings.
- ◆ Tank with customized Volumes available on Request

Item Code	Tank Capacity
NFF-FE-MFU-FA	100 Liters
	150 Liters
	200 Liters





- ◆ Ideal for Fixed Installation
- ◆ Made out of Carbon Steel heavy duty seamless pipe, hot dip galvanized for Corrosion Resistance
- ◆ Design that ensures ease of operation and maintenance
- ◆ Vertical and Horizontal movement is due to Gunmetal or optional Stainless Steel Swivel Joints with Ball Bearing. Tiller Bar fixed on the Barrel is used to move the Monitor to desired position and then threaded Locks are tightened to secure the monitor at a desired horizontal and vertical position
- ◆ For Monitors with Higher Flows, Horizontal and Vertical Movement is made with the Self Locking type enclosed Geared Swivel Joints with Worm and Worm Gear using Hand Wheel that ensures smooth and easy movement during ongoing operation of Monitor.
- ◆ Monitor is capable of Horizontal Rotation of 360 Degrees and Vertical Traverse of + 90 Degrees to -45 Degrees
- ◆ Flanged Inlet – Dimensions as per Requirement
- ◆ Available with variety of Nozzles – Solid Bore Jet Nozzle, Hollow Jet-Fog Nozzle, Self-Aspirating and Self Inducting
- ◆ Foam Barrel and Self Inducting Aqua Foam Nozzle
- ◆ Nozzle Material of Construction is available in Aluminium Alloy, Stainless Steel and Gunmetal
- ◆ ISI Marked IS : 8442 : 1977 (Reaffirmed 1996)
- ◆ Trolley Mounting with Inlets containing Non-Return Valve Optional

Item Code # NFF-M-WJM

Size	Flow	Horizontal Jet @ 30 Deg. Elevation @ 7 Bar	Horizontal Rotation	Vertical Rotation
63mm	1750 LPM	53 mtr.	360°	+80° to +90°
75mm	2580 LPM	60 mtr.	360°	+80° to +90°
100mm	3500 LPM	64 mtr.	360°	+80° to +90°

Long Range Water Monitor



- ◆ Ideal for Fixed Installation
- ◆ Made out of Carbon Steel heavy duty seamless pipe, hot dip galvanized for Corrosion Resistance
- ◆ Design that ensures ease of operation and maintenance
- ◆ For High Volume Monitors, Horizontal and Vertical Movement is made with the Self Locking type enclosed Geared Swivel Joints with Worm and Worm Gear using Hand Wheel that ensures smooth and easy movement during ongoing operation of Monitor.
- ◆ Monitor is capable of Horizontal Rotation of 360 Degrees and Vertical Traverse of +90 Degrees to -45 Degrees
- ◆ Flanged Inlet – Dimensions as per Requirement
- ◆ Available with variety of Nozzles – Solid Bore Jet Nozzle, Hollow Jet-Fog Nozzle and Self Inducting Aqua Foam Nozzle
- ◆ Nozzle Material of Construction is available in Aluminium Alloy, Stainless Steel and Gunmetal

Item Code # NFF-M-LRHV

Barrel Size	Flow @ 7 kg/cm ²	Nozzle	Nozzle Material of Construction
100 MM	1000 GPM	Solid Bore Jet Jet - Fog Aqua Foam	Aluminium Alloy Stainless Steel Gunmetal
100 MM	1250 GPM		
150 MM	1500 GPM		
150 MM	2000 GPM		

Portable Oscillating Monitor - Ranger

Item Code # NFF-M-Ranger

- ◆ The portable oscillating monitor is designed for a dual use of Ground Monitor as well as Deck Monitor with an optional oscillating monitor that can be deployed easily.
- ◆ Lightweight Aluminium Construction monitor with Nominal flow of 1800 LPM @ 7 bar
- ◆ The monitor is equipped with a selectable Gallonage nozzle with a maximum flow range of 1800 LPM @ 7 bar
- ◆ Capabilities of 360 Degree Horizontal Rotation and Vertical Traverse of up to 80 Degrees when being used as a Ground Monitor
- ◆ Carrying Handle and Tiller Bar with Rubber Grip for comfortable operation and firm lifting
- ◆ Stainless steel foldable legs with tips to ensure full stability during operation.
- ◆ 2.5" Size double swivel inlet with locking mechanism for mounting and locking the oscillating attachment.
- ◆ The unit is equipped with a vertical stop pull pin to limit its vertical movement to 30° for safety reasons.
- ◆ The vertical movement beyond 30° is possible by pulling the vertical stop pull pin.
- ◆ The unit is equipped with a pressure gauge and is powder coated in RED.
- ◆ Screw locks for securing the unit at desired Horizontal and Vertical position.
- ◆ The unit is equipped with an optional oscillating attachment which is mounted on to the double swivel inlet of the monitor through a locking mechanism. The oscillating attachment works on Pelton Wheel – Planetary Gear Mechanism. The range of oscillations is from 0° to 60°. The oscillating mechanism avoids complex valve block design and any water lines exposed on the body of monitor. The oscillating mechanism has an oscillating arm to control the Degree of Oscillations. The frequency of oscillations is controlled through a locking gear on the Pelton Wheel. The mechanism is simple to understand, easy to operate and unobstructive to water flow. The oscillating mechanism works even when used with water containing solid particles.
- ◆ Attachments like Ladder Pipes and Flanges for Stand post mounting is optional accessory available on request.



Portable Water Foam Monitor - Commando

Item Code # NFF-M-Commando

- ◆ Multiple usage portable ground monitor converts into Deck / Standpost type by just detaching from swivel joint and adding direct mounting flange easily.
- ◆ Quick locking system enables positive locking and trouble-free assembly.
- ◆ Standard supply is with 2 nos. inlets, 63 mm (2.1/ 2") Male instantaneous as per IS: 903 / BS: 336.
- ◆ Single waterway with built-in turning vanes to minimize turbulence and Auto Drain facility to drain water at low pressure.
- ◆ In case of accidental lift or improper balancing, a foot connected to the
- ◆ Butterfly valve closes, maintaining 10% of water flow, thus reducing the Reaction force.
- ◆ 240° horizontal rotation in Deck / Stand post mode and 180° rotation in Portable mode.
- ◆ Vertical traverse +35° to +90° with safety lock and -45° to +90° after removal of safety lock, in Deck / Standpost mode.
- ◆ Flowrate up to 2400 lpm @7kg / Cm²
- ◆ Stainless steel foldable legs with spikes for sturdy ground base and easy Mobility.
- ◆ Aluminium anodized Jet / Spray fog nozzle designed for powerful jet and thick fog, ensuring protection to the fireman.
- ◆ Also available with Aqua Foam Nozzle, self inducting type, with 3 mtrs. long foam pick-up tube and foam control valve.



Flow Rate @ 7 kg/cm ²	Up to 2400 LPM (630 GPM)
Horizontal Water throw @ 35°	55 mtr.
Horizontal Foam throw @ 35° (Aqua Foam Nozzle)	45 mtr.
Foam Induction Rate (Aqua Foam Nozzle)	3 % Preset
Size : Base folded	53 x 22 x 22 cm.
Weight : Monitor Assembly without Nozzle	19 kgs.

Trailer Mounted Monitor



Item Code # NFF-M-TMFT

- ◆ Ideal for Applications like Rapid Response under Emergency, Backup and Stand by Placements, Protection of Hazard Remotely Located, Temporary Placements where mobility is prime concern
- ◆ Selection of Trailer is made for the Monitors with Large Flow Rate to channelize the Thrust and Reaction Forces generated during Operation.
- ◆ Design of the Trailer is dependent on the Capacity of Monitor along with load of accessories
- ◆ Heavy Duty Mild Steel or Stainless Steel Construction using Tubes and Angles for lower centre of Gravity
- ◆ Single or Double Solid Beam Axle on elliptical springs with Solid Rubber or Pneumatic Tubeless Tyres with Parking Brake arrangement
- ◆ Heavy Duty Rotating and Retracting Castor at the front for easy Steering and manoeuvrability
- ◆ 4 Nos. Thread Locking Type or Optional Geared Stabilizing Jacks.
- ◆ Hot Dip Galvanized Carbon Steel or Stainless Steel Manifold with required number of Inlets
- ◆ Inlets with Built in Non Return Valve or Isolating Ball Valves.
- ◆ Towing Hook for easy hauling behind Jeep or Fire Vehicle.
- ◆ Suitable Locker arrangement with the capacity of up to 20 Nos of 63 MM X 15 Metres Fire Water Delivery Hose Pipe with Couplings and Tool Box for Stowage.
- ◆ Reflectors at the Front and Back are Standard with optional Electric Fittings like Brake Light, Side Signals and Flood Light etc
- ◆ Trailers are specifically designed for mounting of Foam Storage Tanks with necessary fittings with up to Capacity of 5000 Litres.

Trolley Mounted Monitor



Item Code # NFF-M-TMM

- ◆ Ideal for Applications like protection of Hazard Remotely Located, Temporary and Standby Placements where mobility is prime concern
- ◆ Heavy Duty Mild Steel Structure with Solid Rubber Tyres with low center of Gravity for stability
- ◆ Stabilizing Jack
- ◆ Easy Movement and Operation by a Single Person
- ◆ Manifold with Gunmetal British Standard Instantaneous Inlet with Non Return Valve
- ◆ Number of Inlets would depend on the Flow Capacity
- ◆ Ideal for flows up to 3500 LPM.

Standpost Mounted Oscillating Monitor



- ◆ NewAge's oscillating flange readily transforms a manual monitor into an oscillating monitor
- ◆ Oscillating movement is generated through a pelton wheel driven by water power
- ◆ Designed for refineries, process plants, tank farms, tank loading areas, offshore installation and other high-risk areas
- ◆ Carbon steel / brass waterways
- ◆ Oscillating range from 0 to 270 degrees
- ◆ Un-manned operation
- ◆ Oscillating mechanism available in gunmetal or stainless steel
- ◆ Suitable for use with NewAge Carbon steel / Stainless Steel / Gunmetal Monitors

Item Code	Description
NFF-M-OM	500 GPM @ 7 bar with 3" waterways with Jet-Spray Nozzle
	750 GPM @ 7 bar with 3" waterways with Jet-Spray Nozzle
	1000 GPM @ 7 bar with 4" waterways with Jet-Spray Nozzle

Adjustable Flow Monitors

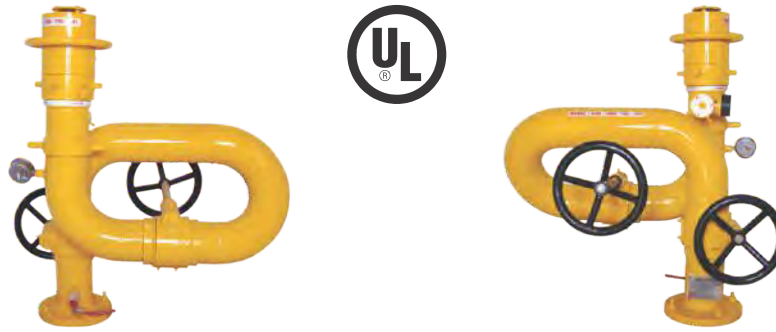

- ◆ UL Listed Monitor and UL Listed Foam Induction Mechanism under UL Standard - 162
- ◆ NewAge UL Listed Water cum Foam Monitors offer superior durability in Marine, Chemical, Oil & Gas Sector, Ports, Jetties, Onshore and Offshore Platforms
- ◆ Designed for Fixed Installations where Monitors are required with High Flow Rates and Long Range Straight Streams.
- ◆ UL Listed Flanged Inlet Monitors with Variable Flow Nozzles
- ◆ Made out of Stainless Steel, these monitors are fit for optimum performance where environment is highly corrosive
- ◆ Stainless Steel Material Grade available are SS 304, SS 316 and SS 316L
- ◆ 3 % Foam Induction is through Self Inducing Non-Aspirating Aqua Foam Nozzle with Jet and Fog Movement and optionally using Jet Ratio Controller Pump.
- ◆ Metering Valve on the Foam Inducing device for Corresponding Flow and Precise Induction
- ◆ Non-Aspirating Aqua Foam Nozzle is very much compatible for Jet-Ratio controller Pump without any modification
- ◆ Selectable Gallonage Nozzle with Multiple Flow Settings capable of adjustment from Straight Stream to 140 Degree Spray Angle
- ◆ The Flow setting can be done easily and quickly from the Monitor Nozzle by an ergonomic Wheel Nut by a Single Operator without the use of any Tools and Tackles
- ◆ The design of the Nozzle is such that change of Flow from one setting to another can occur during the operation of monitor under pressurized condition without shutting down the monitor or isolating the line
- ◆ Horizontal and Vertical Movement is made with the Self Locking type enclosed Geared Swivel Joints with Worm and Worm Gear using Hand Wheel that ensures smooth and easy movement during ongoing operation of Monitor easily by Single Operator
- ◆ Horizontal Rotation of 360 Degrees and Vertical Traverse of +90 Degrees and -45 Degrees
- ◆ The Monitor is equipped with the Pressure Gauge at the Inlet of the Nozzle and a Drain Valve at the Inlet Flange

Item / Part	Material Construction
Nozzle	Stainless Steel-304 / 316 / 316L
Monitor Body	Stainless Steel-304 / 316 / 316L
Flange (150 LBS, ANSI B 16.5 rating size 150 mm)	Stainless Steel-304 / 316 / 316L
Swivel Joints	Stainless Steel-304 / 316 / 316L
Gear	Stainless Steel-304 / 316 / 316L
Spindle for worm	Stainless Steel-304 / 316 / 316L
Hand-wheels for Nozzle, horizontal / vertical movement.	Stainless Steel-304 / 316 / 316L
Pick-up tube (3mtr length)	PVC reinforced with high tensile steel wire helix as per ASTM D1785 sch.80.
Drain Valve	Stainless Steel-304 / 316 / 316L
Foam strainer (removable type)	Stainless Steel-304 / 316 / 316L
Foam Inductor	Stainless Steel-304 / 316 / 316L
Foam Inductor Coupling (63mm)	Stainless Steel-304 / 316 / 316L
Nuts/bolts at monitor	Stainless Steel-304 / 316 / 316L

Monitor Barrel Size	Monitor Nozzle Flow Rate @ 7 KG / CM ²	Foam Induction	Approval
75 MM	500-750 GPM Variable Flow	Self Inducing Nozzle or JRCP	UL Listed
100 MM	500-750-1000 GPM Variable Flow	Self Inducing Nozzle or JRCP	UL Listed
150 MM	1000-1500-2000 GPM Variable Flow	Self Inducing Nozzle or JRCP	UL Listed
200 MM	2000-3000-4000 GPM Variable Flow	JRCP	UL Listed



- ◆ UL Listed Monitor and UL Listed Foam Induction Mechanism under UL Standard - 162
- ◆ NewAge UL Listed Water cum Foam Monitors offer superior durability in Marine, Chemical, Oil & Gas Sector, Ports, Jetties, Onshore and Offshore Platforms
- ◆ Designed for Fixed Installations where Monitors are required with High Flow Rates and Long Range Straight Streams
- ◆ UL Listed Flanged Inlet Monitors with UL Listed Fixed Flow (Gear as well as lever Operated)
- ◆ Made out of Stainless Steel, these monitors are fit for optimum performance where environment is highly corrosive
- ◆ Stainless Steel Material Grade available are SS 304, SS 316 and SS 316L
- ◆ 3 % Foam Induction is through Self Inducting Non-Aspirating Aqua Foam Nozzle with Jet and Fog Movement and optionally using Jet Ratio Controller Pump
- ◆ Metering Valve on the Foam Inducting device for Corresponding Flow and Precise Induction
- ◆ Non-Aspirating Aqua Foam Nozzle is very much compatible for Jet-Ratio controller Pump without any modification
- ◆ Selectable Gallonage Nozzle with Multiple Flow Settings capable of adjustment from Straight Stream to 140 Degree Spray Angle
- ◆ The Flow setting can be done easily and quickly from the Monitor Nozzle by an ergonomic Wheel Nut by a Single Operator without the use of any Tools and Tackles
- ◆ The design of the Nozzle is such that change of Flow from one setting to another can occur during the operation of monitor under pressurized condition without shutting down the monitor or isolating the line
- ◆ Horizontal and Vertical Movement is made with manual Lever / Hand Wheel that ensures smooth and easy movement during ongoing operation of Monitor easily by Single Operator
- ◆ Horizontal Rotation of 360 Degrees and Vertical Traverse of +90 Degrees and -45 Degrees
- ◆ The Monitor is equipped with the Pressure Gauge at the Inlet of the Nozzle and a Drain Valve at the Inlet Flange

Item / Part	Material Construction
Nozzle	Stainless Steel-304 / 316 / 316L
Monitor Body	Stainless Steel-304 / 316 / 316L
Flange (150 LBS, ANSI B 16.5 rating size 150 mm)	Stainless Steel-304 / 316 / 316L
Swivel Joints	Stainless Steel-304 / 316 / 316L
Gear / Lever	Stainless Steel-304 / 316 / 316L
Spindle for worm	Stainless Steel-304 / 316 / 316L
Hand-wheels for Nozzle, horizontal / vertical movement.	Stainless Steel-304 / 316 / 316L
Pick-up tube (3mtr length)	PVC reinforced with high tensile steel wire helix as per ASTM D1785 sch.80.
Drain Valve	Stainless Steel-304 / 316 / 316L
Foam strainer (removable type)	Stainless Steel-304 / 316 / 316L
Foam Inductor	Stainless Steel-304 / 316 / 316L
Foam Inductor Coupling (63mm)	Stainless Steel-304 / 316 / 316L
Nuts/bolts at monitor	Stainless Steel-304 / 316 / 316L

Monitor Barrel Size	Monitor Nozzle Flow Rate @ 7 KG / CM ²	Foam Induction	Approval
75 MM	500 GPM	Self Inducting Nozzle	UL Listed
75 MM	750 GPM	Self Inducting Nozzle	UL Listed
100 MM	1000 GPM	Self Inducting Nozzle or JRCP	UL Listed

Remote Operated Monitors

Fixed Flow Monitors / Adjustable Flow Monitors



- ◆ NewAge Remote Control Monitors are used when Asset is vulnerable and exposed to High Risks especially when reach of Operator or Firemen is limited like Processing towers in Refinery, Conveyers in Power Plants, Confined Storage Areas, Columns in Chemical Plants etc
- ◆ Selection of Fully Electric and Hydraulic-Electric versions
- ◆ Fully Electric Versions are available with 12V & 24V DC Supply that is ideal for Mobile Applications like Fire Vehicle, Riot Control Vehicle, Air Crash Tenders, Marine etc.
- ◆ 3 Phase and 1 Phase AC Supply versions are available for Fixed Installations Applications like Oil & Gas, Chemical Plants and Jetty etc.
- ◆ Electric Components with Ex-d (Flame Proof / Explosion Proof) Certifications like ATEX, PESO and CIMFR for Applications in Hazardous Area.
- ◆ Monitors with Remote Control Mechanism can be stand-alone or Multiple Monitors can be controlled with single control panel
- ◆ Specially developed Electronics that could cut down massive costs on cabling up to 90 %
- ◆ Customized Operation Logic that could allow use of Primary Panel and Secondary Panel with Automatic Override Function.
- ◆ Motor Operated Isolation Valve and Wireless Transmitter for Safe Area as well as ATEX Approved for Hazardous Area optionally available
- ◆ Control Interface are available in Primary Panel, Secondary Panel, Tethered / Wired Control Unit, Wireless Transmitter



- ◆ Available in different flow capacities
- ◆ Self Inducting, Non aspirating type
- ◆ Spray angle upto 160 degrees
- ◆ Induction 3% or 6% (preset)
- ◆ Foam expansion 4 to 6 times
- ◆ Maximum working pressure 10 bar

Item Code	Inlet Connection	Flow @ 7 Bar	Material of Construction
NFF-MN-AQF	2.5" BSP / NH (F) Threads	475 GPM	Gunmetal Stainless Steel Aluminum Alloy
		500 GPM	
		625 GPM	
		750 GPM	
	3.5" BSP / NH (F) Threads	1000 GPM	
		1250 GPM	
		1250 GPM	
	Flanged	2000 GPM	
		4000 GPM	

Aqua Foam Nozzle With Teeth



- ◆ Available in different flow capacities
- ◆ Self Inducting, Non aspirating type
- ◆ Spray angle upto 160 degrees
- ◆ Induction 3% preset
- ◆ Foam expansion 4 to 6 times
- ◆ Maximum working pressure 10 bar

Item Code	Flow @ 7 Bar	Material of Construction
NFF-MN-AFN	500 GPM	Gunmetal Stainless Steel Aluminum Alloy
	750 GPM	
	1000 GPM	
	1500 GPM	
	2000 GPM	
	4000 GPM	

Jet Nozzle

- ◆ Available in different flow capacities
- ◆ Flanged or threaded inlets available
- ◆ Maximum working pressure 10 bar

Item Code	Inlet Connection	Flow @ 7 Bar	Material of Construction
NFF-MN-JN	2.5" BSP / NH (F) Threads	475 GPM	Gunmetal Stainless Steel Aluminum Alloy
		500 GPM	
		625 GPM	
		750 GPM	
	3.5" BSP / NH (F) Threads	1000 GPM	
		1250 GPM	
		1250 GPM	
	Flanged	2000 GPM	
		4000 GPM	
4000 GPM			



Stackble Tips Jet Nozzle

Item Code # MN-STJ

- ◆ The Stacked Tip Nozzle is constructed from lightweight anodized aluminum.
- ◆ These smooth bore tips are a great option for ball shutoff nozzles and give quick availability to increase tip size quickly and effectively.
- ◆ Inlet Threads - NH/NST
- ◆ Base - 2 1/2"
- ◆ Bottom tip orifice - 2"
- ◆ Second tip orifice - 1 3/4"
- ◆ Third tip orifice - 1 1/2"
- ◆ Top tip orifice - 1 3/8"



Jet & Spray Nozzle



- ◆ Available in different flow capacities
- ◆ Flanged or threaded inlets available
- ◆ Spray Angle upto 160 degrees
- ◆ Maximum working pressure 10 bar

Item Code	Inlet Connection	Flow @ 7 Bar	Material of Construction
NFF-MN-JSN	2.5" BSP / NH (F) Threads	475 GPM	Gunmetal Stainless Steel Aluminum Alloy
		500 GPM	
		625 GPM	
		750 GPM	
	3.5" BSP / NH (F) Threads	1000 GPM	
		1250 GPM	
	Flanged	1250 GPM	
		2000 GPM	
		4000 GPM	

Foam Barrel



- ◆ Available with builtin foam inductor or without foam inductor
- ◆ Induction 3% or 6%
- ◆ Foam expansion 6 to 10 times
- ◆ Maximum operating pressure 10 bar
- ◆ Flanged inlets also available

Item Code	Inlet Connection	Flow @ 7 Bar	Material of Construction	Options
NFF-MN-FB	2.5" BSP / NH (F) Threads	475 GPM	Gunmetal Stainless Steel Aluminum Alloy	Jet Jet - Spray
		500 GPM		
		625 GPM		
		750 GPM		
	3.5" BSP / NH (F) Threads	1000 GPM		
		1250 GPM		

Jet Ratio Controller



- ◆ It is a venture-type device to feed large volumes of foam from a safe location to a self-inducing nozzle.
- ◆ Supplied in conjunction with matched aqua foam nozzles
- ◆ Compatible to be used with UL Listed water cum foam monitor
- ◆ Corrosion resistance excellent compatibility with AFFF foam
- ◆ With pressure gauge and pick-up tube
- ◆ Covered in stainless steel 304/316 casing for easy handling and storage

Item Code	Induction	JRCP Inlet Pressure	Working Distance
NFF-MN-JRCP	3%	7 Bar	60 to 100 mtrs.

NKLP 2000/3000/4000

- ◆ Meets the requirements as per BIS Standards
- ◆ Compact and Low Maintenance Design
- ◆ Available with a choice of Primers – Manual or Automatic
- ◆ Perfect Interchangeability of pump spares
- ◆ Available with Stainless Steel or Gunmetal Constructions
- ◆ CE Certified to EN-1028 - 1 & 2 & other Harmonious Standards
- ◆ Fully Compliant to NFPA 1901

N K Fire® Pumps are designed for high performance and reliability. N K Fire® offers pumps of modern design suitable for Fire Brigade Services, Petroleum and Oil Gas Sectors and other Industries.

Pump Body	Impeller	Impeller Shaft	Wear Rings	Shaft Seal	Intake	Discharge Outlets
Gunmetal Stainless Steel Aluminium	Gunmetal Stainless Steel	Stainless Steel	Bronze Stainless Steel	Maintenance Free Mechanical Seal	100 mm 140 mm Round Threaded	4 Way Manifold Option

Description	NKLP 2000	NKLP 3000	NKLP 4000
Rated Performance	2250 LPM @ 8.5 Bar 2000 LPM @ 10 Bar	3200 LPM @ 8.5 Bar 3000 LPM @ 10 Bar	4500 LPM @ 8.5 Bar 4000 LPM @ 10 Bar
Maximum Shaft Speed	3600 RPM	3600 RPM	3600 RPM
Maximum Suction Lift	8 Meters	8 Meters	8 Meters
Suction Inlet	100 mm	140 mm	140 mm



NKLP 6000/10000

- ◆ Meets the requirements as per BIS Standards
- ◆ Compact and Low Maintenance Design
- ◆ Available with a choice of Primers – Manual or Automatic
- ◆ Perfect Interchangeability of pump spares
- ◆ Available with Stainless Steel or Gunmetal Constructions
- ◆ CE Certified to EN-1028 - 1 & 2 & other Harmonious Standards
- ◆ Fully Compliant to NFPA 1901

N K Fire® Pumps are designed for high performance and reliability. N K Fire® offers pumps of modern design suitable for Fire Brigade Services, Petroleum and Oil Gas Sectors and other Industries.

Pump Body	Impeller	Impeller Shaft	Wear Rings	Shaft Seal	Intake	Discharge Outlets
Gunmetal Stainless Steel Aluminium	Gunmetal Stainless Steel	Stainless Steel	Bronze Stainless Steel	Maintenance Free Mechanical Seal	140 mm 200 mm Round Threaded	6 Way Manifold Option

Description	NKLP 2000	NKLP 3000
Rated Performance	6500 LPM @ 10 Bar	10,000 LPM @ 10 Bar
Maximum Shaft Speed	3600 RPM	3600 RPM
Maximum Suction Lift	8 Meters	8 Meters
Suction Inlet	1 X 200 mm 2 X 140 mm	1 X 200 mm 2 X 140 mm



NKMP 2000/3000/4000/6000

- ◆ Meets performance requirements as per BIS Standards
- ◆ Compact and Low Maintenance Design
- ◆ Available with a choice of Primers - Manual or Automatic
- ◆ Easy and convenient mountings
- ◆ Perfect Interchangeability of pump spares
- ◆ Available with Stainless Steel or Gun Metal Constructions
- ◆ CE Certified to EN-1028 - 1 & 2 other Harmonious Standards
- ◆ Fully Compliant to NFPA 1901

N K Fire® Multipressure Fire Pumps are designed for high performance and reliability. N K Fire® offers pumps of modern design suitable for Fire Brigade Services, Petroleum and Oil Gas Sectors and other Industries. N K Fire® manufactures Pumps with Discharge Capacities upto 6,000 LPM on Low Pressure and 400 LPM on High Pressure Side

Pump Body	Impeller	Impeller Shaft	Wear Rings	Shaft Seal	Intake	Safety Valve	Discharge Outlets
Gunmetal Stainless Steel Aluminium	Gunmetal Stainless Steel	Stainless Steel	Bronze Stainless Steel	Maintenance Free Mechanical Seal	140 mm 200 mm Round Threaded	Thermal Relief Valve Pressure Relief Valve	6 Way Manifold Option

Description	NKMP 2000	NKMP 3000	NKMP 4000	NKMP 6000
Rated Performance (Low Pressure)	2250 LPM @ 8.5 Bar 2000 LPM @ 10 Bar	3200 LPM @ 8.5 Bar 3000 LPM @ 10 Bar	4500 LPM @ 8.5 Bar 4000 LPM @ 10 Bar	6500 LPM @ 8.5 Bar 6000 LPM @ 10 Bar
Rated Performance (High Pressure)	400 LPM @ 40 Bar	400 LPM @ 40 Bar	400 LPM @ 40 Bar	400 LPM @ 40 Bar
Maximum Shaft Speed	3600 RPM	3600 RPM	3600 RPM	3600 RPM
Maximum Suction Lift	8 Meters	8 Meters	8 Meters	8 Meters
Suction Inlet	100 mm	140 mm	140 mm	200 mm



Ultra High Pressure Pump - Engine Driven

The high pressure unit produces fine mist at 100 bar which greatly increases cooling and extinguishing properties of water. Water consumption is drastically reduced and extinguishing operation accelerated. The revolutionary technology decreases the fire knock down time drastically.



Item Code # NFF-PU-UHP (ENGINE)

- ◆ Available in 100 Bar and 150 Bar Pressure versions
- ◆ Foam Induction from 0 – 6% (Optional)
- ◆ Auto Throttle Control (Optional)
- ◆ Pistol Grip Nozzles for Water and Foam (with foam attachment)
- ◆ Diesel Versions available on request

Engine	14 HP (Petrol)	18 HP (Petrol)
Pump	Plunger Pump	Plunger Pump
Capacity	42 LPM	42 LPM
Pressure	100 Bar	150 Bar

Ultra High Pressure Pump - PTO Driven



The high pressure pump can be connected to the Power Take Off unit of Fire Truck to obtain flows as high as 150 Litres per Minute with a pressure of 100 Bar. Higher flow provides for a better throw and reach.

- ◆ Available in 3 Plunger and 6 Plunger versions
- ◆ Foam Induction from 0 – 6% (Optional)
- ◆ Pistol Grip Nozzles for Water and Foam (with foam attachment)

Item Code # NFF-PU-UHP (PTO)

Pump	Three Plunger Pump	Six Plunger Pump
Capacity	150 LPM	152 LPM
Pressure	100 Bar	100 Bar



Low Capacity Fire Fighting Pump

Diesel Driven Low Capacity Fire Pump designed for continuous fire fighting, dewater, and tank refilling purposes.

Single Cylinder, 4 Strokes, Air Cooled Diesel Engine of 6 - 7 HP. A well-designed hand-starting device to ensure reliable and quick starting engine. Available in Manual as well as Electronic Start.



Item Code # NFF-PU-LC

Pump	Light Alloy	Light Alloy
Engine	Diesel	Diesel
Starting	Manual	Electronic Start

Trailer Mounted Fire Pump

Skids for slide in units for Pickup trucks as well as Stand Alone units available. These systems are best in remote areas where water resource is available but a hydrant network is not available.

- ◆ Diesel Engine Driven
- ◆ For continuous duty application
- ◆ Available in Skid, Slide-In or Trailer Versions
- ◆ Can be used for Fire Fighting as well as De-watering
- ◆ Engine Options include Cummins / Ashok Leyland / Tata



Item Code # NFF-PU-TM

Capacity	1800 LPM	2400 LPM	3000 LPM	4000 LPM
Engine Diesel	4 Cylinder	4 Cylinder	6 Cylinder	6 Cylinder

Ejector Pump



- ◆ Material of Construction : Aluminum Alloy
- ◆ Working Pressure : Max. 145 PSI, Min. 72 PSI
- ◆ Feed Water Inlet : 2 1/2" Instantaneous
- ◆ Suction Inlet : 4" BSRT Male Thread
- ◆ Suction Outlet : 4" BSRT Male Thread
- ◆ Max. Suction Depth : 10 Meters

Item Code	Performance
NFF-PU-EP	170 GPM @ 100 PSI

Adjustable Ejector Pump



- ◆ The adjustability features, make it possible to vary the angle of throw of water for effective operation
- ◆ Material of construction : Aluminum Alloy
- ◆ Working Pressure : Max. 10 Bar, Min. 5 Bar
- ◆ Suction Inlet : 2 1/2" Male Instantaneous
- ◆ Suction Outlet : 2 1/2" Female Instantaneous

Item Code	Feed Water Flow	Flood Water Flow
NFF-FU-AEP	66 GPM @ 100 PSI	140 GPM @ 6 Meter Head

Turbo Pump



- ◆ It is a water turbine driven centrifugal pumps
- ◆ Turbine inlet and outlet - 2 1/2" female instantaneous
- ◆ Pump Outlet - 2 1/2" female instantaneous
- ◆ Strainer Brass
- ◆ Feed water flow - 225 GPM @ 100 PSI
- ◆ Flood water flow - 330 GPM @ 100 PSI

Item Code	Material of Construction
NFF-PU-TP	Gummetal
	Aluminum Alloy

Metal Suction Strainer

Item Code	Description
NFF-ACC-MSS	3" BSRT in Brass
	4" BSRT in Brass
	4" BSRT in Aluminum Alloy



Basket Strainer

Item Code	Description
NFF-ACC-BSK	Cane



Rubber Suction Hose

Item Code
NFF-ACC-PSH/RSH



Fireman Axe



Item Code
NFF-ACC-AXE

Belt & Pouch



Item Code
NFF-ACC-BLT

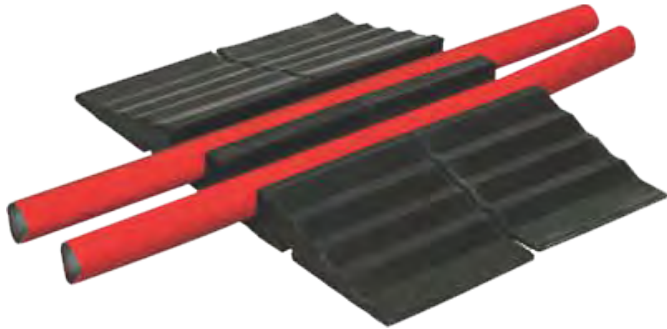

- ◆ Material : Reinforced solid Rubber
- ◆ Load Capacity : 20000 Kg
- ◆ Capacity : 2 × 2 ½" hose
- ◆ Weight : 15.5 Kg

Item Code	Description
NFF-HME-HRP	860 mm × 300 mm × 85 mm Size

Hose Washing Machine



- ◆ Operating Pressure - 7 bar
- ◆ Material Aluminum Alloy
- ◆ Inlet - 2 ½" Male Inst.
- ◆ Washes hose with Coupling

Item Code	Description
NFF-HME-HWM	860 mm × 300 mm × 85 mm Size

Manual Hose Binding Machine

- ◆ Binding on with wire delivery hose & suction hoses to coupling
- ◆ Complete with one adapter male & female for 2 1/2", 3" & 4"

Item Code	Description
NFF-HME-HWM	860 mm × 300 mm × 85 mm Size

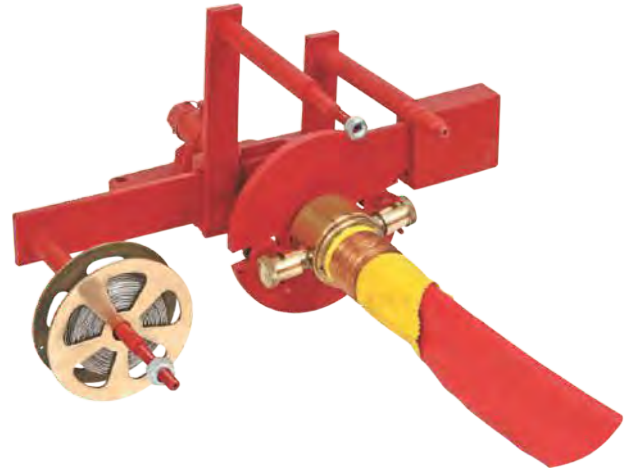

Electric Hose Binding Machine

- ◆ Complete Arrangements for riveting, binding with tool kit & adapter
- ◆ Complete set of adapters 2 1/2", 3" & 4"
- ◆ Table with drawer arrangement
- ◆ One person can easily operate Low maintenance
- ◆ Available in 220 of 440 volts

Item Code
NFF-HME-EHB



Hand Operated Siren



- ◆ Cradel Mounted
- ◆ Made out from Aluminum Alloy
- ◆ Range : 1.6 Km

Item Code
NFF-SRN-HO

Fire Bell



- ◆ Made Out from special Bell material
- ◆ Size : 10"
- ◆ Completed with suspension and strike

Item Code
NFF-SRN-FB

Electric Siren



- ◆ Available in Horizontal and Vertical mounted
- ◆ Made out from Aluminum Alloy
- ◆ 12 VDC or 24 VDC V or 440 VAC operated
- ◆ Audiable Range in KM is 0.10 to 16

Item Code
NFF-SRN-EO

Smoke Generator



Smoke Generator is a compact, portable, high performance and reliable smoke machine, capable of producing a large volume of dense, white, non-toxic, non-irritant, non-flammable oil based smoke used particularly by fire brigades, health authorities, Army forces and the entertainment field.

1. Model: NI 210A

Power	: AC100V/AC120V/AC230V/AC240V, 50Hz-60Hz
Heater	: 1,000 W
Output	: 10,000 cu.ft/min
First Heat-Up Time	: 5.5 min.
Tank Capacity	: 1.7 liters
Fluid Consumption Rate	: 18 min/liter
Remote Included (Fogging Switch: ON / OFF)	
Accessory Included	: Hanging Bracket
Weight	: 6.6 kg
Dimensions (mm)	: L 433 W 198 H 151

2. Model: NI 210B

Power	: AC100V/AC120V/AC230V/AC240V, 50Hz-60Hz
Heater	: 1,500 W
Output	: 20,000 cu.ft/min
First Heat-Up Time	: 8.5 min.
Tank Capacity	: 6 liters
Fluid Consumption Rate	: 9 min/liter (100% output)
Remote Included (LCD Time Remote)	
Weight	: 14 kg
Dimensions (mm)	: L 688 W 285 H 188

Water Driven Positive Pressure Ventilator

- ◆ It is water turbine driven smoke extractor fan
- ◆ Corrosion resistance stainless steel construction
- ◆ Light weight, Portable
- ◆ Inlet and outlet are 2 ½” Instantaneous
- ◆ 3 meter long P.V.C. collapsible ducting for carrying smoke



Item Code	Description
NFF-SET-WD	Smoke Extract 55 M ³ / min at 100 PSI Water Inlet Pressure

Engine Driven Positive Pressure Ventilator

NewAge's PPV fans are for the fire personals who need a high quality PPV fan. The units are able to create maximum airflow because of their mighty engines that offer the highest horsepower in their class. They are easily transportable and space saving as they are designed to compact dimensions of fire / rescue apparatus.

- ◆ Light Weight Design
- ◆ High Air Flow
- ◆ Honda Engines
- ◆ Easy to maintain



Item Code # NFF-SET-EGD

Model	Engine	HP	Fan Size	Weight	Dimensions (mm) (L x W x H)	Air Flow (m ³ /hour)
NFF-GS-16"	Honda	5.5	400 mm x 17 blades	27 Kgs	533 x 508 x 432	19810
NFF-GS-21"	Honda	5.5	540 mm x 7 blades	40 Kgs	641 x 616 x 495	30039
NFF-GS-24"	Honda	5.5	600 mm x 9 blades	52 Kgs	737 x 711 x 531	46750

Electric Driven Positive Pressure Ventilator

NewAge's Electrically Operated PPV fans are for the fire personals who need a high quality PPV fan. The Units are a single speed, electric, positive pressure fan. They are easily transportable and space saving as they are designed to compact dimensions of fire / rescue apparatus.

- ◆ Light Weight Design
- ◆ High Air Flow
- ◆ Robust Electric Motors for Heavy Duty Application
- ◆ Easy to maintain

Item Code # NFF-SET-ED

Model	Amps (Start / Run)	Power	Fan Size	Weight	Dimensions (mm) (L x W x H)	Air Flow (m ³ /hour)
NFF-EX-16"	18 / 5	1.2 kW 230 V 50Hz-1Ø	400 mm x 17 blades	26 Kgs	480 x 460 x 320	10360
NFF-EX-20"	18 / 5	1.2 kW 380 V 50Hz-1Ø	500 mm x 9 blades	38 Kgs	650 x 630 x 430	16150
NFF-EX-24"	18 / 5	1.5 kW 380 V 50Hz-1Ø	600 mm x 9 blades	47 Kgs	730 x 710 x 490	18360



Water Tender



Manufactured as per IS: 950 primarily. Can be customized to suit individual requirements

- ◆ Water Tank available in Stainless Steel, GRP as well as Mild Steel
- ◆ Superstructure options include Mild Steel, Stainless Steel, Extruded Aluminium Profiles & GRP
- ◆ Tank mounted on Subframe with Metacones
- ◆ MCD France made Aluminium Roller Shutters with LED Lighting optionally available
- ◆ Electronic Tank Level Indicators optionally available
- ◆ Fully Pneumatic Valve Control with CAN BUS System available optionally
- ◆ Gear Box PTO mounted Ultra High Pressure Pump installation optionally available

Foam Tender



Manufactured as per IS: 10460 primarily. Can be customized to suit individual requirements

- ◆ Water & Foam Tanks available in Stainless Steel, GRP as well as Mild Steel
- ◆ Varieties of Foam System available
- ◆ Superstructure options include Mild Steel, Stainless Steel, Extruded Aluminium Profiles & GRP
- ◆ Tanks mounted on Subframe with Metacones
- ◆ MCD France made Aluminium Roller Shutters with LED Lighting optionally available
- ◆ Electronic Tank Level Indicators optionally available
- ◆ Gear Box PTO mounted Ultra High Pressure Pump installation optionally available

DCP Tender



Manufactured as per IS: 10993 primarily. Can be customized to suit individual requirements

- ◆ DCP System available in 250 – 4000 Kgs Capacity
- ◆ CO₂ System available in multiples of 22.5 Kgs Capacity
- ◆ DCP Vessels made as per ASME Code Section VIII of ASTM SA -516 (Grade 70) Plates
- ◆ Superstructure options include Mild Steel, Stainless Steel, Extruded Aluminium Profiles & GRP
- ◆ DCP System mounted on Subframe
- ◆ MCD France made Aluminium Roller Shutters with LED Lighting optionally available

Mini High Pressure Tender

Meant for Narrow Lane as well as Forest Fire Fighting. Can be customized to suit individual requirements

- ◆ Vehicle made on 2 – 7 Ton GVW Chassis
- ◆ PTO Driven Ultra High Pressure Pump of 70 or 150 LPM @ 100 bar or optionally Engine Driven Ultra High Pressure Pump of 42 LPM @ 100 Bar available
- ◆ Superstructure options include Mild Steel, Stainless Steel, Extruded Aluminium Profiles & GRP
- ◆ Tanks mounted on Subframe with Metacones
- ◆ MCD France made Aluminium Roller Shutters with LED Lighting optionally available
- ◆ Electronic Tank Level Indicators optionally available



Water Bouser

Meant for replenishing Water to front line fire tenders. Can be customized to suit individual requirements

- ◆ Vehicle made on 25 – 31 Ton GVW Chassis
- ◆ PTO Driven Ultra High Pressure Pump of 70 or 150 LPM @ 100 bar optionally available
- ◆ Superstructure options include Mild Steel, Stainless Steel, Extruded Aluminium Profiles & GRP
- ◆ Tanks mounted on Subframe with Metacones
- ◆ MCD France made Aluminium Roller Shutters with LED Lighting optionally available
- ◆ Electronic Tank Level Indicators optionally available



Multi Purpose Tender

Manufactured as per IS 10460 primarily. Can be customized to suit individual requirements

- ◆ Water & Foam Tanks available in Stainless Steel, GRP as well as Mild Steel
- ◆ Varieties of Foam System available
- ◆ DCP System available in 50 – 2000 Kgs Capacity
- ◆ CO₂ System available in multiples of 22.5 Kgs Capacity
- ◆ Superstructure options include Mild Steel, Stainless Steel, Extruded Aluminium Profiles & GRP
- ◆ Tanks mounted on Subframe with Metacones
- ◆ MCD France made Aluminium Roller Shutters with LED Lighting optionally available
- ◆ Electronic Tank Level Indicators optionally available
- ◆ Gear Box PTO mounted Ultra High Pressure Pump installation optionally available



Rescue & Hazmat Tender



Manufactured as per IS 949 primarily. Can be customized to suit individual requirements

- ◆ Vehicle made on 2 – 31 Ton GVW Chassis (Fast Attack, Light Duty, Medium Duty & Heavy Duty)
- ◆ Superstructure options include Mild Steel, Stainless Steel, Extruded Aluminium Profiles & GRP
- ◆ MCD France made Aluminium Roller Shutters with LED Lighting optionally available
- ◆ Roll – in Roll – out Drawers with Self Locking System for storing equipments
- ◆ Carries Generators, Breathing Air Equipments, Water Rescue, Lighting Equipments, Flood Rescue Equipments as well as Disaster Rescue Equipments.

Foam Nurser



Meant for replenishing Foam to front line fire tenders. Can be customized to suit individual requirements

- ◆ Vehicle made on 16 – 31 Ton GVW Chassis
- ◆ Foam Pump of 500 - 1600 LPM @ 12 - 16 bar available
- ◆ Varieties of Foam System available
- ◆ Superstructure options include Mild Steel, Stainless Steel, Extruded Aluminium Profiles & GRP
- ◆ Tank mounted on Subframe with Metacones
- ◆ MCD France made Aluminium Roller Shutters with LED Lighting optionally available
- ◆ Electronic Tank Level Indicators optionally available

Cabin Extensions



Original Factory manufactured Chassis cabins are extended to include crew cabins. Can be customized with various individual requirements.

- ◆ The strength, shape and looks of the original cabin with fittings remains unchanged.
- ◆ Fully tilting cabin with original factory mechanism modified to carry extra weight
- ◆ Can include up to 6 crew members
- ◆ Various Seating Options including BA Set Backrest Seats available

Hydraulic Platform - VEMA



State of the Art – Fire Fighting & Rescue Platforms are manufactured by Vema Lift Oy., Finland

- ◆ Platforms are certified to EN1777 and EN280
- ◆ Available from working heights of 19 – 70 meters
- ◆ Unique Three Boom Design System meant for better reaches and versatility of operations
- ◆ Self Diagnostic System for easy maintenance and trouble shooting
- ◆ Stainless Steel Bodywork
- ◆ Optional attachments and accessories include Generators, Breathing Air Equipments, Hydraulic Rescue Equipments, Escape Chute, Thermal Imager as well as Video Camera with recorder, Stretcher Carrier etc.

TFL Series

Models	Working Height	Outreach	Cage Load
273 TFL	27.5 mtrs	21.0 mtrs	400 Kgs
323 TFL	32.0 mtrs	21.0 mtrs	400 Kgs
333 TFL	33.0 mtrs	25.5 mtrs	400 Kgs
383 TFL	38.0 mtrs	22.0 mtrs	400 Kgs
453 TFL	45.0 mtrs	26.0 mtrs	400 Kgs
553 TFL	55.0 mtrs	23.0 mtrs	450 Kgs

F Series

Models	Working Height	Outreach	Cage Load
28 F	28.5 mtrs	24.0 mtrs	500 Kgs
32 F	32.0 mtrs	24.0 mtrs	500 Kgs
34 F	34.0 mtrs	25.0 mtrs	500 Kgs
38 F	38.0 mtrs	25.0 mtrs	500 Kgs

Combi Series

Models	Working Height	Outreach	Cage Load
192 TF	19.0 mtrs	13.5 mtrs	280 Kgs
242 TF	24.0 mtrs	13.5 mtrs	280 Kgs
282 TF	28.0 mtrs	16.0 mtrs	280 Kgs

Water Foam Tower (TWT Series)

Models	Working Height	Outreach
28 F	28.5 mtrs	24.0 mtrs
32 F	32.0 mtrs	24.0 mtrs
34 F	34.0 mtrs	25.0 mtrs
38 F	38.0 mtrs	25.0 mtrs

DCP Skid / Trailer



Skids for slide in units for Pickup trucks as well as Stand Alone units available. Can also be connected to existing fire detection system and piping.

- ◆ Tank made of ASTM A 516 Grade 70
- ◆ Can be used as a compact stationary fire extinguisher, to be used with Hose reel or with fixed piping system
- ◆ Can be manually or electronically actuated. The system is Nitrogen Propelled.
- ◆ Extremely Fast Charging Times
- ◆ Agent Capacity of 150 to 4000 Kilograms available
- ◆ Available in Skid, Slide-In or Trailer Versions
- ◆ Available with Options of Hose Reel Lengths

150 kgs	250 kgs	300 kgs	500 kgs	1000 kgs	1500 kgs
---------	---------	---------	---------	----------	----------

Twin Agent Skid

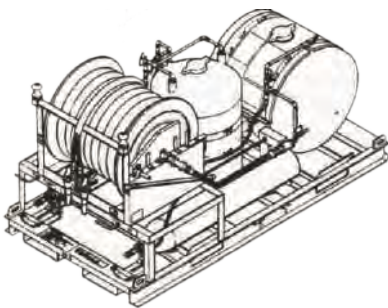

Skids for slide in units for Pickup trucks as well as Stand Alone units available. These systems are best used where no source of electricity, pump or engine for pumping and propulsion are available.

- ◆ Dry Chemical Powder
 - NFPA 17 Compliant
 - Purple K / UL Listed Urea Based DCP
 - Nitrogen Propelled
- ◆ Foam System
 - NFPA 11 Compliant
 - AFFF / AR-AFFF – 3% / 6%
 - Nitrogen Propelled
- ◆ Available in Skid, Slide-In or Trailer Versions
- ◆ Available with Options of Hose Reel Lengths

DCP / Foam	(Kgs / Litres)				
		100 / 300	250 / 650	500 / 650	1000 / 800

- ◆ Also available in custom sizes

Fire Pump Skid



Skids for slide in units for Pickup trucks as well as Stand Alone units available. These systems are best in remote areas where water resource is available but a hydrant network is not available.

- ◆ Diesel Engine Driven
- ◆ For continuous duty application
- ◆ Can be used for Fire Fighting as well as De-watering
- ◆ Engine Options include Cummins / Ashok Leyland / Tata

Capacity	1800 LPM	2400 LPM	3000 LPM	4000 LPM
Engine Diesel	4 Cylinder	4 Cylinder	6 Cylinder	6 Cylinder

Foam Skid With Inline Balance Proportioning System

Skids for slide in units for Pickup trucks as well as Stand Alone units available. These systems are available in various configurations including a foam pump of various sizes.

- ◆ Tanks available in Stainless Steel as well as GRP
- ◆ Inline Balance Pressure Proportioning System Optional
- ◆ Available with an option of Foam Pump or a Foam Inductor
- ◆ Foam Pump can be Electric, Engine Driven or Hydraulically Driven
- ◆ Foam Pumps available from 20 GPM to 300 GPM



Foam Tank Capacity (Litres)	100	250	500	800	1000	1500	2000
With ILBP (Inches)	3"	4"	6"	8"	10"	12"	

*Also available in custom sizes

CAFS Skid

Skids for slide in units for Pickup trucks as well as Stand Alone units available. These systems are available in various configurations including a customized nozzle flow and hose reel lengths.

- ◆ Tanks available in Stainless Steel as well as GRP
- ◆ Nitrogen Expelled Systems
- ◆ System Designed with or without a Mixing Chamber
- ◆ Specialized Nozzles with foam cone (when system is used without Mixing Chamber) available
- ◆ Various Hose Reel Lengths available

Capacity (Litres)	100	250	500	800	1000	1500	2000
--------------------------	-----	-----	-----	-----	------	------	------

- ◆ Also available in custom sizes

Leak Sealing Bandages



NewAge brings you world class Environmental Protection Products from **SAVATECH, D.O.O., Slovenia.**

Leak Sealing Bandages are required to seal leaking pipes and other cylindrical shaped containers ranging from 50 - 480 mm diameter. The bandages are made with a highly chemical-resistant rubber compound, which also retains a high level of flexibility for the most demanding applications. They will comply to the following technical specifications:

Bandage	Sizes			Size Usage Range	Inflation Pressure (Bar)	Weight (Kgs)
	Width	Length	Height			
SB 1	125	250	10	50 - 80	1.5	2.1
SB 2	125	980	10	50 - 200	1.5	3.5
SB 3	210	980	10	50 - 200	1.5	3.9
SB 4	210	1700	10	200 - 450	1.5	6.7
SB 5	250	800	10	50 - 180	1.5	4.3
SB 6	450	650	10	50 - 180	1.5	5.5
SB 7	450	1300	10	100 - 350	1.5	9.1
SB 8	450	1700	10	200 - 450	1.5	11.1

Leak Sealing Kits



NewAge brings you world class Environmental Protection Products from **SAVATECH, D.O.O., Slovenia.**

For quick and efficient sealing of barrels, pipes and tanks for diameters larger than 500 mm. Sealing bag M1 has two openings on each side for pulling straps while the M2 sealing plug has two swivel eyelet bolts instead. Large Leak Sealing Kit is suitable for quick and efficient sealing of barrels, pipes and tanks for diameters larger than 500 mm. They are equipped with quick coupling for inflation and deflation. The Leak Sealing Kit will have the following technical data:

Dimensions (mm)	620 x 300 x 20
Sealing surface (mm)	450 x 235
Max. Inflation Pressure (bar)	1.5
Sealing Pressure (bar)	1.4
Volume (Litres)	20
Weight (Kg)	5.0

The Kit shall comprise of the following:

Description	Quantity
Leak Sealing Bag	1
Foot pump with safety valve, 1,5 bar	1
Inflation Hose, 10 m, Blue, with Chain & Deflation Nipple	1
Tensioning & Extension Belt with Ratchet, 10 m, Yellow	2
Tensioning & Extension Belt with Ratchet, 10 m, Orange	2
Sealing Plate, 600 mm x 300 mm x 25 mm	2
Sealing Plate, 1000 mm x 300 mm x 25 mm	1
Acid Protection Cover	1

Leak Sealing Pipe Plugging Kit



NewAge brings you world class Environmental Protection Products from **SAVATECH, d.o.o., Slovenia.**

The Pipe Plug Leak Sealing Kit will be a combination of Elliptical Plugs & Pneumatic Pipe Plugs with assorted accessories. They will comply to the below technical data :

Elliptical Plugs :

Size	Usage Diameter		Inflation Pressure (Bar)	Deflated Plug Size		Insertion Opening	Weight (Kgs)
	Min.	Max.		Diameter	Length		
50 - 80	45	80	3.0	45	280	35	0.3
80 - 130	75	130	3.5	76	360	40	0.4
100 - 160	100	160	2.0	98	420	45	0.6

Cylindrical Plugs :

Plug	Usage Diameter		Inflation Pressure (Bar)	Deflated Plug Size		Weight (Kgs)
	Min.	Max.		Diameter	Length	
Z 1	20	33	2.5	19	98	0.02
Z 1½	33	40	2.5	32	100	0.07
Z 2/3	46	77	2.5	45	110	0.11
Z ¾	71	102	2.5	70	130	0.25
Z 4/6	86	153	2.5	85	195	0.42

Cylindrical Bypass Plugs :

Size	Usage Diameter		Inflation Pressure (Bar)	Deflated Plug Size		Weight (Kgs)	Bypass Diameter
	Min.	Max.		Diameter	Length		
S 2	46	52	2.5	45	280	110	3
S ¾	71	102	2.5	70	360	130	12.5
S 4/6	86	153	2.5	85	420	195	12.5

The following accessories shall be supplied along :

Description	Quality
Tyre Valve Extension Hose 1 meter	2
Anti Static Inflation Hose 3 meter	1
Static Discharge Kit	1
Mini Hand Pump	1
Shut Off Valve R 1/2	1
Shut Off Valve R 1/8	1
Bag of Assorted Wooden Corks	1
Portable Case	1

Leak Sealing Wedges & Cones

NewAge brings you world class Environmental Protection Products from SAVATECH, d.o.o., Slovenia.

Sealing wedges and cones are used for quick sealing of cracks or slot shaped punctures on ground storage tanks or tankers on trucks and railcars. Three different size wedge shaped plugs must be supplied, which can be used for sealing cracks (15 - 60 mm). One cone shaped plug must be supplied, which can be used for sealing holes 30 - 90 mm diameter. The remote placement pole, (push and inflation rod) and spray deflector is required to install and inflate cones or wedges from a distance. The Wedges and Cones shall require 1.5 bar pressure for inflation. They should comply to the below technical data:



Description	Deflated Size (mm)	Usage Height (mm)	Usage Width (mm)	Max. Weight (Kgs)
Wedge 1	230 x 60 x 50	15 - 45	60 - 80	0.5
Wedge 2	230 x 80 x 55	15 - 45	80 - 110	0.5
Wedge 3	230 x 110 x 70	30 - 60	110 - 170	0.5
Cone	230 x Ø 7	30 - 90	-	0.5

The Kit shall comprise of the following:

Description	Quantity
Wedge Shaped Sealing Bags of Sizes as above (1 each)	3
Cone Shaped Sealing Bag	1
Push & Inflation Rod, 350 mm, with Chain & Deflation Nipple	1
Push & Inflation Rod, 350 mm	3
Shut Off Unit	1
Foot Pump with Safety Valve, 1.5 bar	1
Portable Pelican Case 600 mm x 400 mm x 135 mm	1
Splash Protection Disk	1

Pneumatic Lifting Bags



NewAge brings you world class Rescue Protection Products from **SAVATECH, d.o.o., Slovenia.**



The high pressure lifting bags are Kevlar Chord Reinforced High Quality Alloy Rubber made. All the metal parts used are of Brass / Stainless Steel only. The bags have a design inflation pressure of 8 bar and burst pressure higher than 32 bar. The surface of the bag is adequately curled / dimpled to provide grip when the bags are stacked one over the other. The bags meet the following technical data :

Size (max)	mm x mm	300 x 300	450 x 450	550 x 550	550 x 550	700 x 700	950 x 950
Insertion Height (max)	mm	30	30	30	30	30	30
Weight (max)	kg	2.5	5.5	8.5	13.5	18.5	25.5
Lifting Height (min)	mm	150	200	250	350	400	500
Lifting Capacity (min)	Tons	5.5	12.5	20.0	31.0	41.0	65.51
Air Requirement (max)	Litres	45	160	300	650	950	550
Inflation Time (max)	sec	2.0	7.0	15.0	28.0	50.0	80.0

List of Accessories (Standard per Set of 2 Lifting Bags)

Dual Deadman Controller in Plastic Box	1 Unit
10 meter Inflation Hose with Shut Off Valve / Ball Valve (Yellow, Red, Blue)	3 Nos
Pressure Reducer (300 Bar to 8 Bar)	1 No
Compressed Air Cylinder Bottle - 6 Litres (Optional)	1 No

Mini High Pressure Lifting Bag Kit



Mini Lift Kit is a self-contained heavy lift device kit small enough to fit into a car trunk or squad cabinet. First responders can easily carry the kit into remote locations, tight quarters, or thick brush without needing additional support equipment. The kit will contain the following 3 lifting bags:

Size (max)	mm x mm	300 x 300	450 x 450	550 x 550
Insertion Height (max)	mm	30	30	30
Weight (max)	kg	2.5	5.5	8.5
Lifting Height (min)	mm	150	200	250
Lifting Capacity (min)	Tons	5.5	12.5	20.0
Air Requirement (max)	Litres	45	160	300
Inflation Time (max)	sec	2.0	7.0	15.0

List of Accessories

Inflation and safety device with Pressure Reducer, Pr. Gauge, Safety Valve & Inlet	1 Unit
5 meter Inflation Hose	1 Nos
Inflation Distributor with 2 x 1 meter Inflation Hoses	1 No
Portable Pelican Case 600 mm x 400 mm x 135 mm	1 No

Hydraulic Rescue Tools

NewAge brings you world class Hydraulic Rescue Protection Products from **Holmatro BV, The Netherlands**

A wide variety of Cutters, Spreaders, Combination Tools, Rescue Rams and Power Units are available from the Holmatro House.



For more information, please log on to www.holmatro.com

Head Office & Factory

NewAge Fire Fighting Co Ltd.
Ambawadi Industrial Estate,
Surendranagar - 363001 Gujarat, India
Phone: +91 2752 288000

Export Office

513, Amanora Chambers,
East Amanora Park Town,
Hadapsar, Pune - 411028
Phone: +91 2067278500

Website: www.newage-india.in
Email: info@newage-india.in

